

# **WA 125** **(YF-AR 1255)**

---

## User Manual

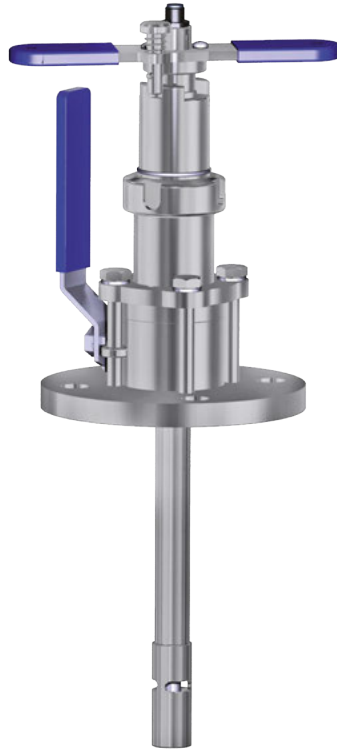

---

### **Sensor Lock-Gate with Ball Valve and 2-Electrode Conductivity Sensor**

---



80921

**Knick** >

---

## **Warranty**

Defects occurring within 1 year from delivery date shall be remedied free of charge at our plant (carriage and insurance paid by sender).

©2010 Subject to change without notice

## **Exclusions from Warranty**

Wear parts (gaskets) and damage caused by improper use are excluded from warranty.

## **Return of Products**

Please contact our Service Team before returning a defective device. Ship the cleaned device to the address you have been given. If the device has been in contact with process fluids, it must be decontaminated/disinfected before shipment. In that case, please attach a corresponding Declaration of Contamination (download from [www.knick.de](http://www.knick.de)), for the health and safety of our service personnel.

# Safety Information

---

WA 125 Sensor Lock-Gate

---



## **Process-Related Risks**

Knick Elektronische Messgeräte GmbH & Co. KG assumes no liability for damages caused by process-related risks known to the operator, which would in fact not permit the use of the WA 125 sensor lock-gate.

### **Be sure to observe:**

Work on the sensor lock-gate must only be performed by personnel authorized by the operating company and specially trained for handling and operating the sensor lock-gate.

## **Warnings**

The device has been developed and manufactured using state of the art technology and it complies with applicable safety regulations. When operating the device, certain conditions may nevertheless lead to danger for the operator or damage to the device. Observe the influence of humidity, ambient temperature, chemicals and corrosion. Prerequisite to safe use of the equipment is the observance of the specified ambient conditions and temperature ranges. If the specifications in the user manual are not sufficient for assessing the safety of operation, please contact the manufacturer to make sure that your intended application is possible and safe.

---

# Table of Contents

---

WA 125 Sensor Lock-Gate

<b>Safety Information .....</b>	<b>3</b>
<b>Intended Use.....</b>	<b>5</b>
<b>Build-up of the Sensor Lock-Gate .....</b>	<b>6</b>
<b>Function Description.....</b>	<b>7</b>
<b>Moving the Sensor to Process Position .....</b>	<b>8</b>
<b>Moving the Sensor to Service Position.....</b>	<b>9</b>
<b>Maintenance Work on the Sensor Lock-Gate .....</b>	<b>10</b>
<b>Leakage Check.....</b>	<b>10</b>
<b>Removing the Sensor .....</b>	<b>11</b>
<b>Installing the Sensor .....</b>	<b>12</b>
<b>Calibrating / Adjusting the Sensor.....</b>	<b>13</b>
<b>Specifications.....</b>	<b>14</b>
<b>Pressure/Temperature Diagram .....</b>	<b>15</b>
<b>Dimension Drawings .....</b>	<b>16</b>
<b>M12 Plug .....</b>	<b>17</b>

# Intended Use

---

## WA 125 Sensor Lock-Gate

The WA 125 manual sensor lock-gate is used for measuring conductivity in liquids. The sensor can be cleaned, calibrated or replaced under process conditions (pressure and temperature). It has a large measuring range up to 1000  $\mu\text{S}/\text{cm}$  and is particularly suitable for monitoring ultrapure water. A temperature detector is integrated in the sensor.



### **Safe Use**

If you are not sure whether the sensor lock-gate can be safely used for your intended application, please contact the manufacturer.

---

To ensure safe use of the equipment, you must follow the instructions given in this manual and observe the specified temperature and pressure ranges.

The WA 125 sensor lock-gate has been developed and manufactured in compliance with the applicable European guidelines and standards.

# Build-up of the Sensor Lock-Gate

---

WA 125 Sensor Lock-Gate

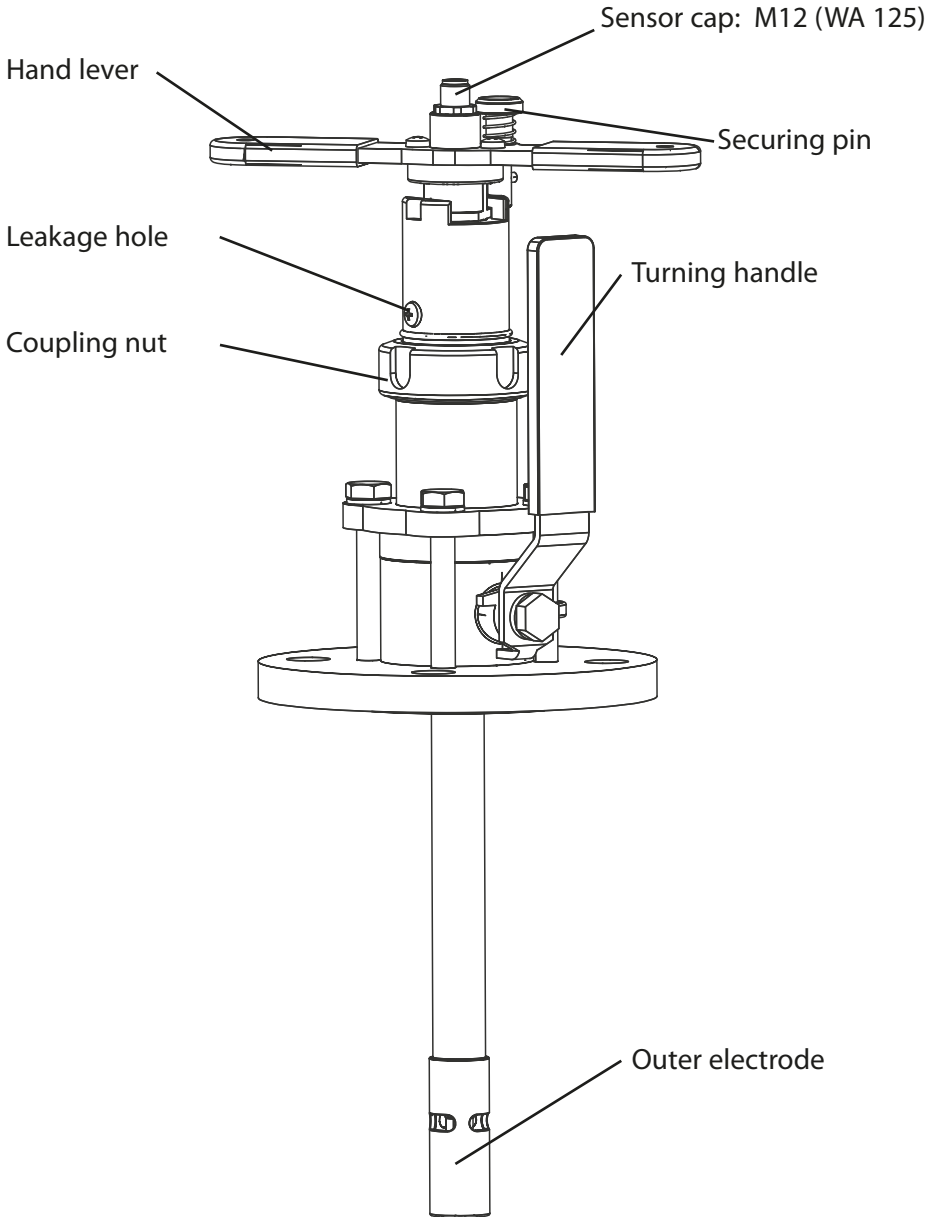

# Function Description

---

## WA 125 Sensor Lock-Gate

The manually operated sensor lock-gate allows calibrating and cleaning the sensor in the running process. For that purpose, the sensor lock-gate can be moved between two positions:

- **PROCESS position:** Sensor located in the process medium.
- **SERVICE position:** Sensor located in the calibration chamber.

In SERVICE position you can clean, maintain, calibrate or adjust the sensor.

The sensor lock-gate consists of two main units:  
sensor unit and process unit.

The sensor unit performs the required movements to move the sensor into and out of the process.

The process unit comprises the process-wetted service chamber as well as the process adaptation. Sensor unit and process unit can be separated by the operator.

The guide bush is provided with a leakage hole. The hole is closed by a screw. If process fluid comes out of the leakage hole as it is opened, the process-side gasket is damaged.

# Moving the Sensor to Process Position

WA 125 Sensor Lock-Gate

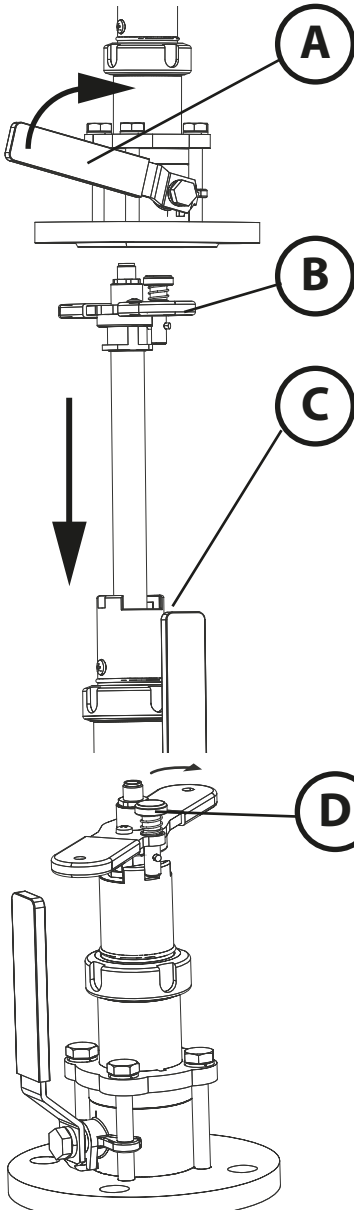

1. Open the ball valve (move turning handle **A** to vertical position).

2. Use hand lever **B** to push the sensor into the process until stop **C** is reached.

3. Then lock the sensor by turning it clockwise as far as possible.

4. Press securing pin **D** and turn it by 90°. The securing pin will snap in and secure the lock.



# Moving the Sensor to Service Position

WA 125 Sensor Lock-Gate

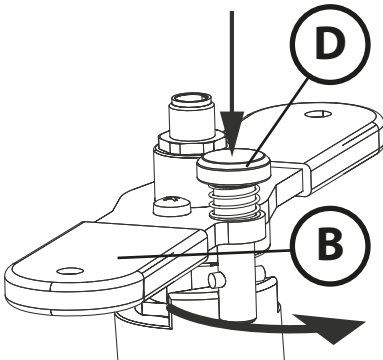

**Caution!** The process pressure pushes the sensor into service position. **Risk of injury!**

1. Press securing pin **D** and turn it by 90°.
2. Turn the sensor counterclockwise using hand levers **B**.

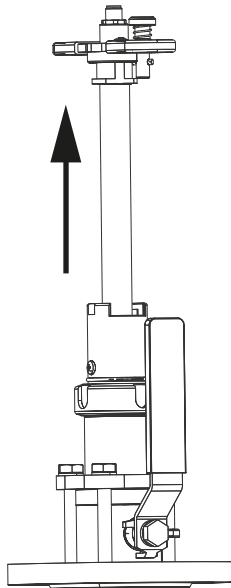

3. Move the sensor to Service position.

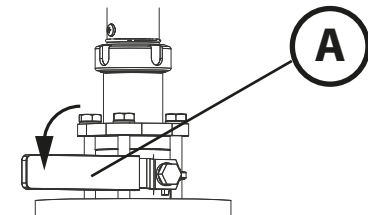

4. Close the ball valve (move turning handle **A** to horizontal position).

# Maintenance Work on the Sensor Lock-Gate

---

## WA 125 Sensor Lock-Gate

The sensor must be removed, for example, for:

- general maintenance or inspection
  - cleaning the sensor
  - replacing and checking the sensor gaskets or slip rings
  - replacing the outer or inner electrode
- 



### **Warning!**

To separate the sensor lock-gate safely from the process, make sure that it is disconnected from all process media and process pressure.

### **Caution!**

Before working on the sensor lock-gate, make sure that the ball valve is closed.

### **Caution!**

Check whether the sensor is completely in Service position before you actuate the ball valve.

### **Caution!**

The outer electrode also serves as a stop. After maintenance work has been completed it must be carefully screwed on again.

### **Warning!**

Process fluid may escape when the leakage hole is opened.

---

## Leakage Check

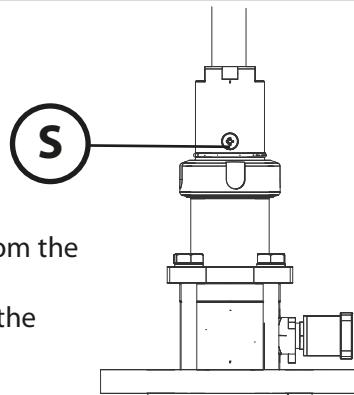

Carefully remove the screw **S** (PH 2) from the leakage hole.

If process fluid comes out, a gasket in the guide bush may be defective.

---

# Removing the Sensor

## WA 125 Sensor Lock-Gate

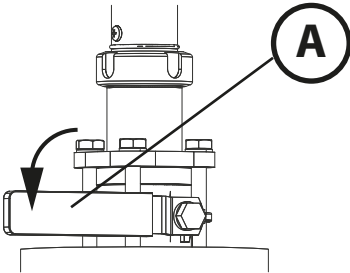

1. Move the sensor to Service position (See "Moving the Sensor to Service Position" on page 9).
2. Close the ball valve (move turning handle **A** to horizontal position).

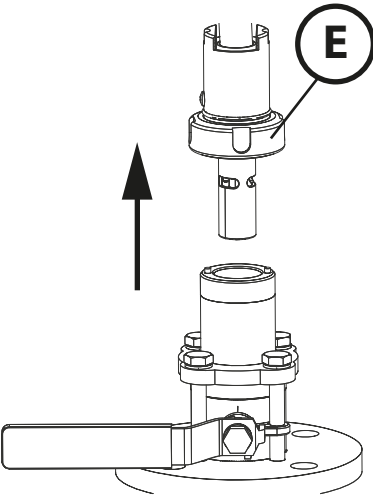

3. Loosen coupling nut **E**.
4. Disconnect the sensor unit from the process unit.

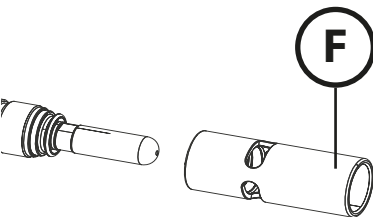

5. Now, you can screw off the outer electrode **F** and clean the sensor.
6. Where appropriate, pull the sensor out of the guide bush to check whether slip rings or gaskets are damaged and replace as necessary.

# Installing the Sensor

---

WA 125 Sensor Lock-Gate

1. Check whether gaskets or slip rings are damaged.  
Replace damaged gaskets or slip rings.
2. Push the sensor in the guide bush and screw on the outer electrode.
3. Place the sensor unit on the process unit and loosely screw on the coupling nut.

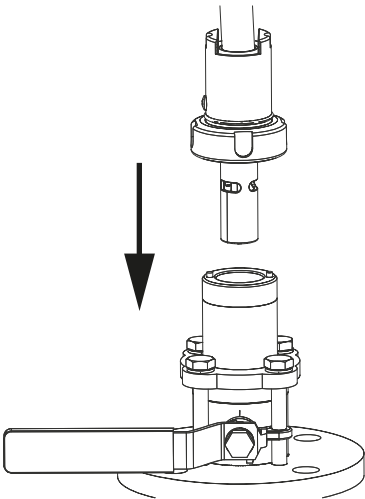

4. Insert the center pins **G** into place and screw the coupling nut tight.

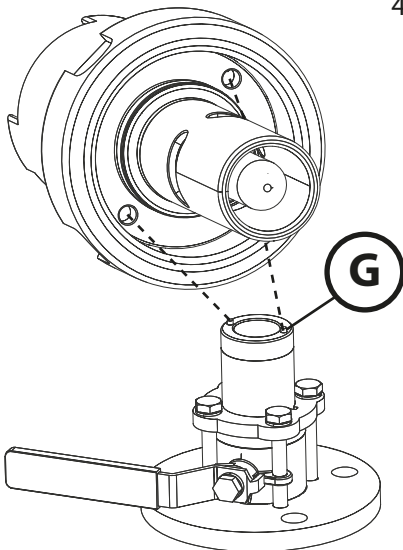

# Calibrating / Adjusting the Sensor

---

WA 125 Sensor Lock-Gate

Remove sensor, clean, rinse and dry it, then immerse it in a calibration solution.

Suitable calibration solution ZU 0350 (15  $\mu\text{S}/\text{cm}$ ), ZU 0702 (147  $\mu\text{S}/\text{cm}$ ).  
Perform a product calibration if the sensor can or shall not be removed.  
Observe instruction manual of meter.

# Specifications

---

## WA 125 Sensor Lock-Gate

<b>Cell constant:</b>	Approx. 0.021 cm <sup>-1</sup>
<b>Measuring range:</b>	
- M12	0.04 ... 1000 μS cm <sup>-1</sup>
- Memosens®	0.04 ... 200 μS cm <sup>-1</sup>
<b>Temperature detector:</b>	
- M12	Pt 1000
- Memosens®	NTC 30 kΩ
<b>Response time:</b>	t <sub>90</sub> < 45 s
<b>Materials:</b>	Housing and electrodes: Stainless steel 1.4571 and 1.4435 Insulator: PEEK Gaskets: EPDM or FKM Ball valve: Stainless steel 1.4408 and 1.4401 PTFE
<b>Temperature:</b>	Process: -30 ... +135 °C Environment: -25 ... +80 °C
<b>Pressure:</b>	Max. 10 bars at -30 ... +135 °C
<b>Sensor connection:</b>	M12, Memosens®
<b>Protection:</b>	IP 67 (with closed connection)
<b>Process connection:</b>	Flange DIN EN 1092-1/B 1/DN 50/PN 16
<b>Immersion depth:</b>	210 mm
<b>Dimensions:</b>	See dimension drawings
<b>Weight:</b>	Approx. 7 kg

# Pressure/Temperature Diagram

---

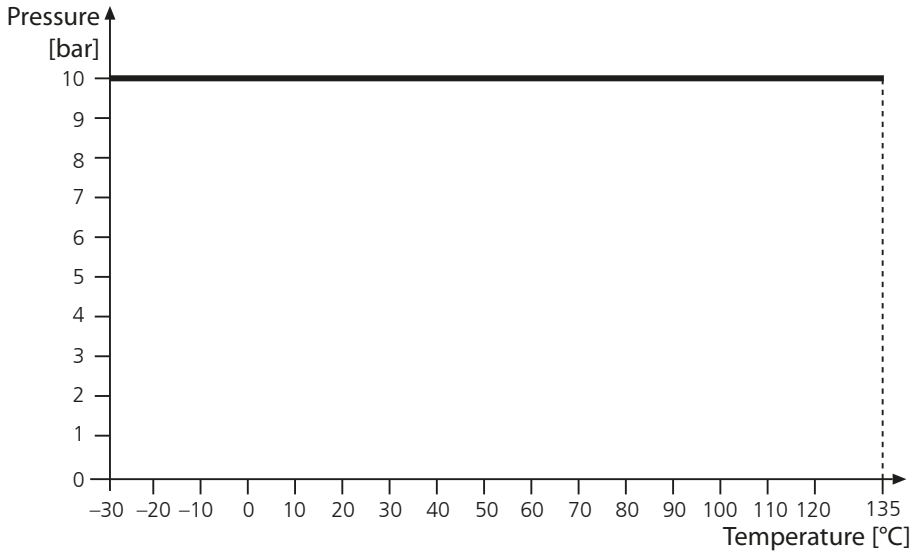

# Dimension Drawings

WA 125 Sensor Lock-Gate

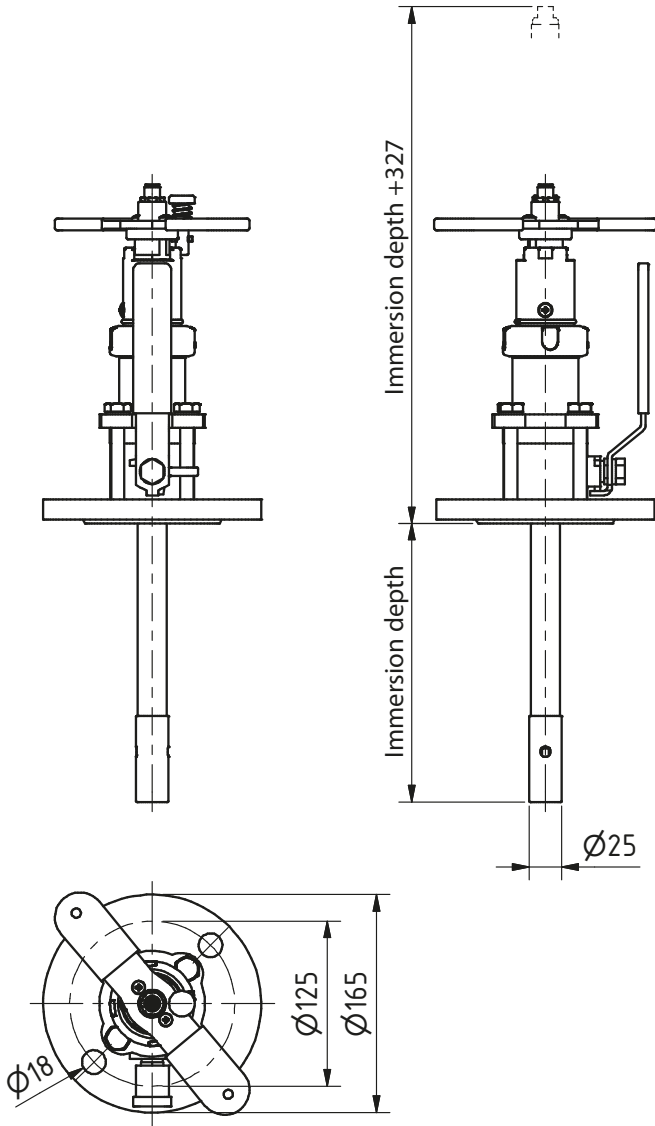

(All dimensions in mm.)



# M12 Plug

WA 125 Sensor Lock-Gate

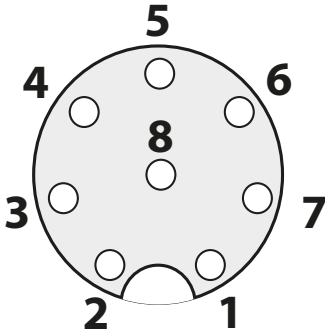

Pin	Color
1	white
2	brown
3	green
4	yellow
5	gray
6	pink
7	blue
8	red

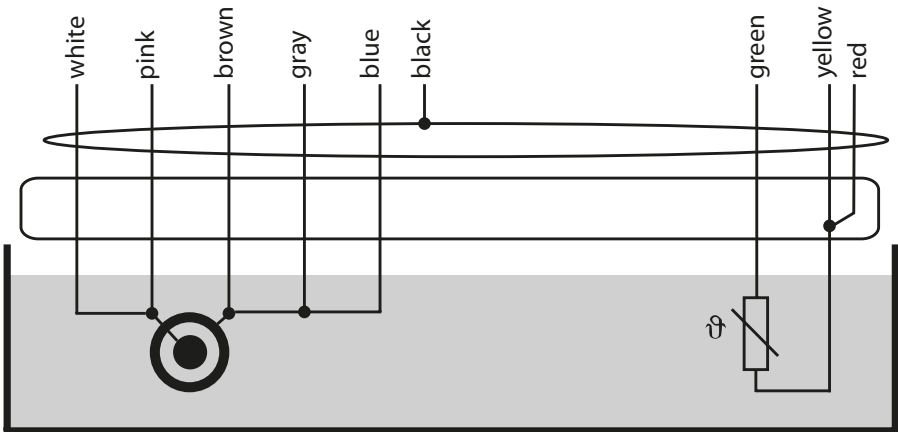





---

**Knick**

**Elektronische Messgeräte GmbH & Co. KG**

P.O. Box 37 04 15

14134 Berlin, Germany



Phone: +49 (0)30 - 801 91 - 0

Fax: +49 (0)30 - 801 91 - 200

Internet: <http://www.knick.de>

[knick@knick.de](mailto:knick@knick.de)

TA-240.000-KNE01

20161005