

SensoGate WA131

Retractable Fitting

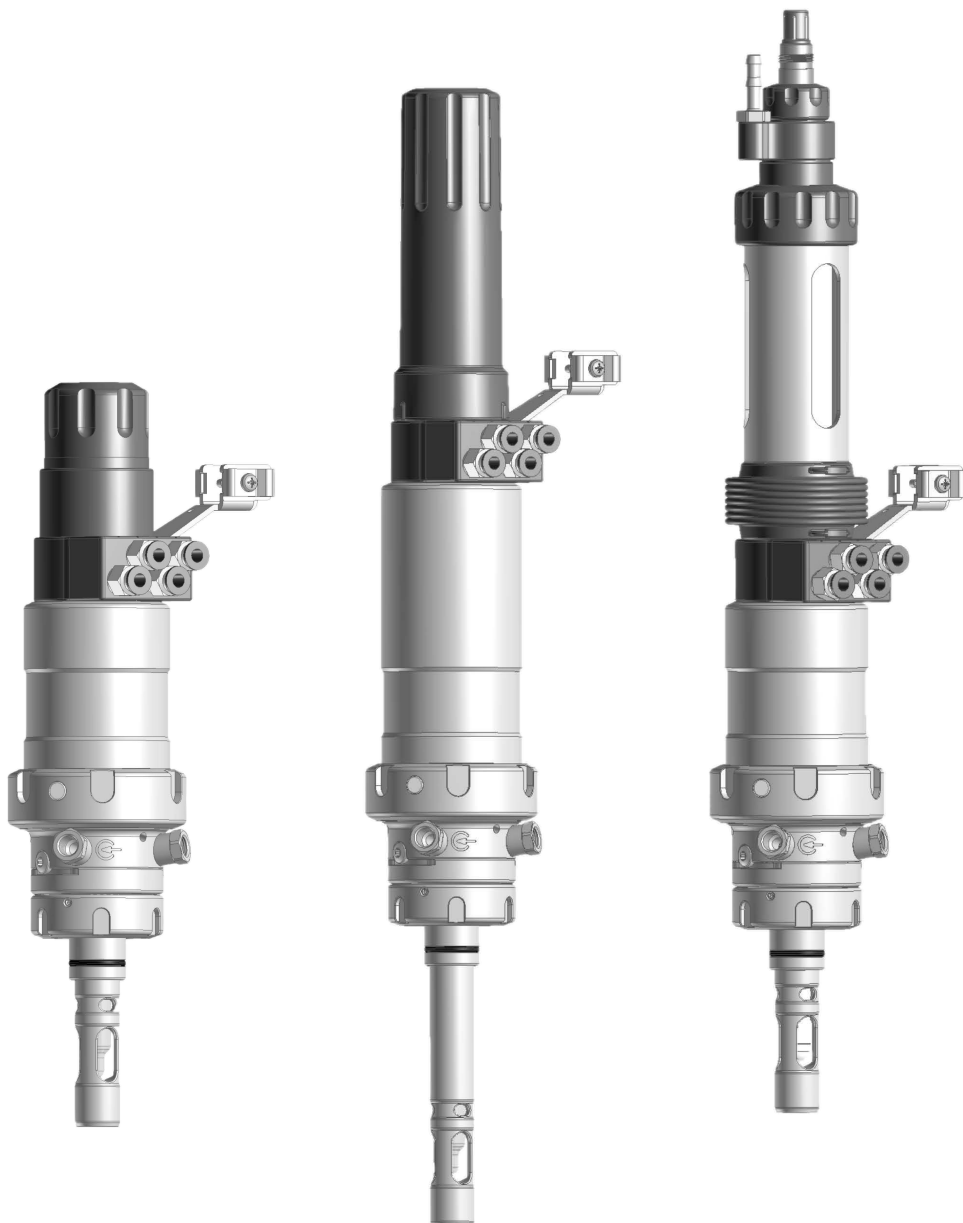

Read before installation.
Keep for future use.



Supplemental Directives

READ AND SAVE THIS DOCUMENT FOR FUTURE REFERENCE. BEFORE ATTEMPTING TO ASSEMBLE, INSTALL, OPERATE OR MAINTAIN THE PRODUCT, PLEASE ENSURE A COMPLETE UNDERSTANDING OF THE INSTRUCTIONS AND RISKS DESCRIBED HEREIN. ALWAYS OBSERVE ALL SAFETY INFORMATION. FAILURE TO COMPLY WITH INSTRUCTIONS IN THIS DOCUMENT COULD RESULT IN SERIOUS INJURY AND/OR PROPERTY DAMAGE. THIS DOCUMENT IS SUBJECT TO CHANGE WITHOUT NOTICE.



These supplemental directives explain how safety information is laid out in this document and what content it covers.

Safety Chapter

This document’s safety chapter is designed to give the reader a basic understanding of safety. It illustrates general hazards and gives strategies on how to avoid them.

Warnings

This document uses the following warnings to indicate hazardous situations:

Symbol	Category	Meaning	Remark
	WARNING	Designates a situation that can lead to death or serious (irreversible) injury.	The warnings contain information on how to avoid the hazard.
	CAUTION	Designates a situation that can lead to slight or moderate (reversible) injury.	
<i>None</i>	NOTICE	Designates a situation that can lead to property or environmental damage.	

Symbols Used in this Document

Symbol	Meaning
→	Reference to additional information
✓	Interim or final result in instructions for action
▶	Sequence of figures attached to an instruction for action
①	Item number in a figure
(1)	Item number in text

Table of Contents

1 Safety	5
1.1 Intended Use	5
1.2 Personnel Requirements	5
1.3 Safeguards.....	6
1.4 Residual Risks	7
1.4.1 Accidental Loosening of the Process Connection	7
1.5 Safety Accessories.....	8
1.6 Hazardous Substances	9
1.7 Operation in Hazardous Locations	9
1.7.1 Possible Ignition Hazards During Installation and Maintenance	9
1.7.2 Possible Ignition Hazards During Operation	10
1.8 Safety Training	10
1.9 Maintenance and Spare Parts.....	10
2 Product	11
2.1 Package Contents	11
2.2 Product Identification.....	11
2.2.1 Model Designation Example	11
2.2.2 Product Code	12
2.3 Nameplates	14
2.4 Symbols and Markings.....	16
2.5 Design and Function.....	16
2.5.1 Retractable Fitting.....	17
2.5.2 Drives and Sensor Holders	18
2.5.3 Process Connections	18
2.5.4 Immersion Tubes	19
2.6 Permissible Changes.....	19
2.7 Service/Process Limit Positions.....	20
2.7.1 Service and Process Position	20
2.7.2 Limit Signals	21
3 Installation	22
3.1 Retractable Fitting: Installation.....	22
3.2 Safety Accessories: Installation	22
3.3 Outlet Hose: Installation	23
3.4 Inlet Hose (Option): Installation	24
3.5 Pneumatic Control: Installation	24
3.6 Protective Pane Option: Installation.....	25
4 Commissioning	26

5	Operation	27
5.1	Moving into the Process Position (PROCESS Limit Position)	27
5.2	Moving into the Service Position (SERVICE Limit Position).....	27
5.3	Installing and Removing Sensors.....	28
5.3.1	Safety Instructions on Installing and Removing Sensors.....	28
5.3.2	Solid-Electrolyte Sensor, Short Immersion Depth: Installation	28
5.3.3	Solid-Electrolyte Sensor, Short Immersion Depth: Removal	29
5.3.4	Solid-Electrolyte Sensor, Long Immersion Depth: Installation	30
5.3.5	Solid-Electrolyte Sensor, Long Immersion Depth: Removal	31
5.3.6	Liquid-Electrolyte Sensor: Installation.....	32
5.3.7	Liquid-Electrolyte Sensor: Removal.....	34
6	Maintenance	35
6.1	Inspection	35
6.1.1	Inspection and Maintenance Intervals	35
6.1.2	Immersion Lock Without a Mounted Solid-Electrolyte Sensor: Functional Test	35
6.1.3	Immersion Lock Without a Mounted Liquid-Electrolyte Sensor: Functional Test	36
6.2	Preventive Maintenance.....	37
6.2.1	Approved Lubricants.....	37
6.2.2	Characteristics of Process-Wetted Materials.....	37
6.3	Corrective Maintenance	38
6.3.1	Corrective Maintenance Safety Instructions	38
6.3.2	Drive Unit: Removal.....	38
6.3.3	Drive Unit: Assembly.....	39
6.3.4	Immersion Tube: Removal	40
6.3.5	Immersion Tube: Installation.....	41
6.3.6	Calibration Chamber: Removal	42
6.3.7	Calibration Chamber: Installation.....	43
6.3.8	Knick Repair Service	43
7	Troubleshooting	44
7.1	Malfunction State: Retractable Fitting Does Not Fully Move to the SERVICE or PROCESS Limit Position	44
8	Decommissioning	45
8.1	Retractable Fitting: Removal.....	45
8.2	Return.....	45
8.3	Disposal.....	45
9	Spare Parts, Accessories, and Tools.....	46
9.1	Seal Kits.....	46
9.2	Spare Parts.....	48
9.3	Accessories	49
9.4	Tools.....	53
10	Dimension Drawings	54
11	Specifications.....	60
	Technical Terms.....	62
	Index.....	63

1 Safety

This document contains important instructions for the use of the product. Always follow all instructions and operate the product with caution. If you have any questions, please contact Knick Elektronische Messgeräte GmbH & Co. KG (hereinafter sometimes referred to as “Knick”) using the information provided on the back page of this document.

1.1 Intended Use

The SensoGate WA131 (the “product”) is a retractable fitting for installation in boilers, tanks, and pipes. The product is used to mount a sensor for measuring process parameters. The sensor is immersed in the process medium by the SensoGate WA131. The SensoGate WA131 is pneumatically operated.

Cleaning, calibration, or sensor replacement under process conditions by the customer (hereinafter sometimes referred to as the “operating company”) may be conducted, subject to the requirements set forth herein, by placing the product into the service position (SERVICE limit position).

If the product is used with any product or part not authorized by Knick, the operating company assumes all risks and liabilities related thereto.

The SensoGate WA131 fitting can be used with the following sensor types:

Solid-electrolyte sensors	Body diameter 12 mm, length 225 mm, sensor head thread PG 13.5
Liquid-electrolyte sensors	Body diameter 12 mm, length 250 mm or 450 mm
Optical sensors	Body diameter 12 mm

For further information, refer to the applicable documentation of the sensor manufacturer.

The defined operating conditions must be observed when using this product. → *Specifications, p. 60*

Thanks to its modular design, the SensoGate WA131 can be adapted to changed conditions by the customer.

→ *Permissible Changes, p. 19*

USE CAUTION AT ALL TIMES WHEN INSTALLING, USING, MAINTAINING OR OTHERWISE INTERACTING WITH THE PRODUCT. ANY USE OF THE PRODUCT EXCEPT AS SET FORTH HEREIN IS PROHIBITED, AND MAY RESULT IN SERIOUS INJURY OR DEATH, AS WELL AS DAMAGE TO PROPERTY. THE OPERATING COMPANY SHALL BE SOLELY RESPONSIBLE FOR ANY DAMAGES RESULTING FROM OR ARISING OUT OF AN UNINTENDED USE OF THE PRODUCT.

The SensoGate WA131-X version is certified for operation in explosive atmospheres.

→ *Operation in Hazardous Locations, p. 9*

1.2 Personnel Requirements

The operating company shall ensure that any personnel using or otherwise interacting with the product is adequately trained and has been properly instructed.

The operating company shall comply and cause its personnel to comply with all applicable laws, regulations, codes, ordinances, and relevant industry qualification standards related to product. Failure to comply with the foregoing shall constitute a violation of operating company’s obligations concerning the product, including but not limited to an unintended use as described in this document.

1.3 Safeguards

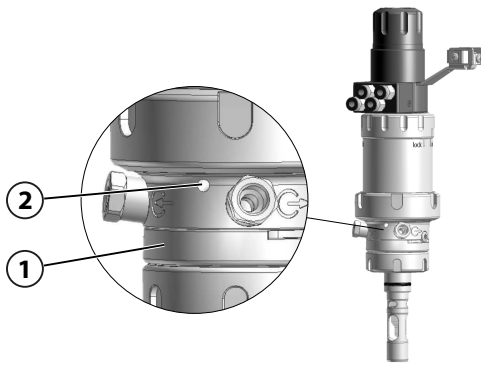

Leakage Bores

The calibration chamber (1) is provided with three radial leakage bores (2).

Process medium escaping from the leakage bores (2) is indicative of damage to the calibration chamber's O-rings. This damage can be detected and repaired.

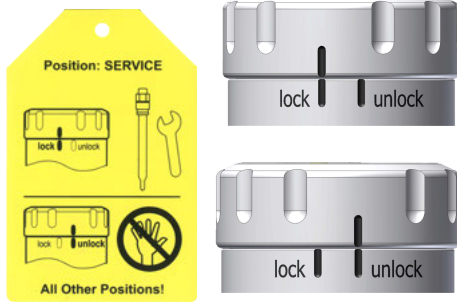

SensoLock Locking

The SensoLock immersion lock prevents the SensoGate WA131 from accidentally moving into the process position (PROCESS limit position).

In the service position (SERVICE limit position), manually setting the SensoLock ring to "lock" locks the SensoGate WA131 and prevents it from moving into the process position (PROCESS limit position).

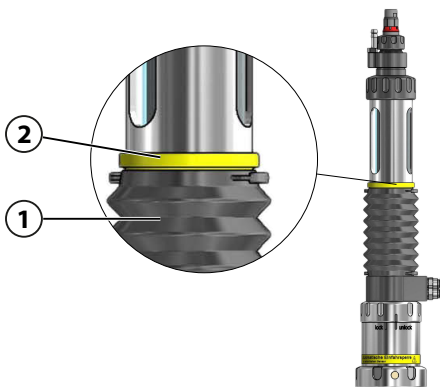

Immersion Lock Without a Mounted Liquid-Electrolyte Sensor

The safeguard is only available with special version V.
→ *Product Code, p. 12*

The immersion lock can be seen at the yellow indicator ring (2) above the bellows (1). If the yellow indicator ring (2) is missing, the safeguard function is not available.

A mechanical lock prevents the SensoGate WA131 without a mounted liquid-electrolyte sensor from being moved into the process position (PROCESS limit position).

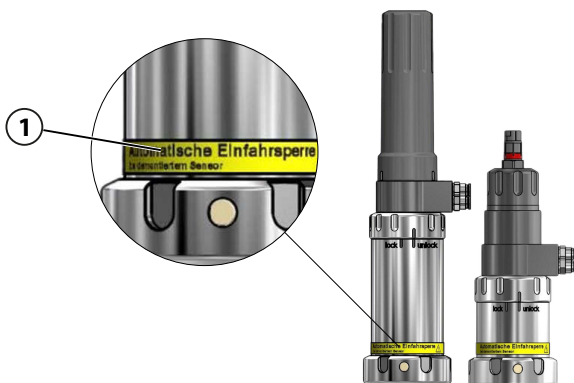

Immersion Lock Without a Mounted Solid-Electrolyte Sensor

The safeguard is only available with special version W.
→ *Product Code, p. 12*

The immersion lock can be seen at the yellow indicator ring (1) on the drive unit of the SensoGate WA131. If the yellow indicator ring (1) is missing, the safeguard function is not available.

A mechanical lock prevents the SensoGate WA131 without a mounted solid-electrolyte sensor from being moved into the process position (PROCESS limit position).

The availability of safeguards is in part dependent on the version of SensoGate WA131.

→ *Product Code, p. 12*

Environmental influences may affect the functionality of safeguards (e.g., components stuck together).

→ *Residual Risks, p. 7*

1.4 Residual Risks

The product has been developed and manufactured in accordance with generally accepted safety rules and regulations, as well as an internal risk assessment. Despite the foregoing, the product may among others bear the following risks:

Environmental Influences

The effects of moisture, ambient temperature, chemicals, and corrosion can negatively impact the safe operation of the product.

Please observe the following instructions:

- If possible, install the product inside a protected area of the plant. Alternatively, take appropriate measures to protect the SensoGate WA131 (e.g., install ZU0759 protective cap¹⁾).
→ *Accessories, p. 49*
- If using aggressive chemical process media, adjust the inspection and maintenance intervals accordingly. → *Inspection and Maintenance Intervals, p. 35*
- Adhering and sticky process media can impact the functionality of the SensoGate WA131 (e.g., by causing components to stick together). Adjust the inspection and maintenance intervals accordingly. → *Inspection and Maintenance Intervals, p. 35*

1.4.1 Accidental Loosening of the Process Connection

Movement of the sensor into the SERVICE/PROCESS limit positions is triggered on the SensoGate WA131 by the pressurization of the control or process air.

Some versions of the SensoGate WA131 are screwed to process connections with a thread or secured with coupling nuts. Travel movements or process-related vibrations may cause the process connection to accidentally come loose from the process or a coupling nut. Pressurized process medium may escape.

Use of an appropriate retainer clamp or locking clamp is strongly recommended.

→ *Safety Accessories, p. 8*

Operating the SensoGate WA131 without a retainer or locking clamp is at the risk of the operating company. The operating company must take action to rule out the possibility of the screw joint coupling nut accidentally loosening.

¹⁾ The ZU0759 protective cap protects against the effects of weather exposure and prevents the ingress of external liquids or particles into the area of the sensor connections.

1.5 Safety Accessories

Specially developed accessories are available to increase safety. → *Accessories, p. 49*



ZU0818 Retainer Clamp for Ingold Socket, 25 mm

The retainer clamp prevents the coupling nut of the Ingold socket (25 mm) screw joint from accidentally coming loose.

The wires of the retainer clamp connect the SensoGate WA131 to the customer's process port. A locking lug on the retainer clamp engages in the groove of the coupling nut (form-fit).

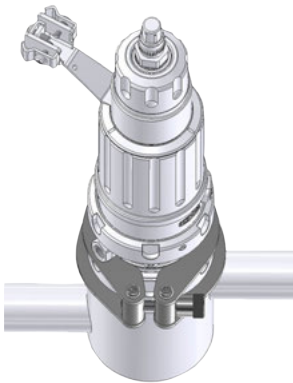

ZU1055 Retainer Clamp for Process Connection K8

The retainer clamp prevents the coupling nut of the screw joint for a K8 process connection from accidentally coming loose.

The wires of the retainer clamp connect the SensoGate WA131 to the customer's process port. A locking lug on the retainer clamp engages in the groove of the coupling nut (form-fit).

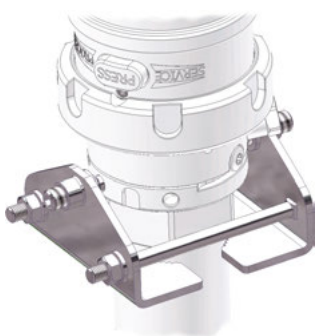

ZU0877 Locking Clamp for Process Connection G1", G1 1/4", R1", R1 1/4", 1" NPT

The locking clamp prevents the process screw joint of a SensoGate WA131 with threaded connection from accidentally coming loose. The locking clamp is available for process connections with the following threads: G1", G1 1/4", R1", R1 1/4", 1" NPT.

The locking clamp can be used with threaded couplings with a minimum length of 10 mm and an outer diameter of 39 mm to 57 mm.

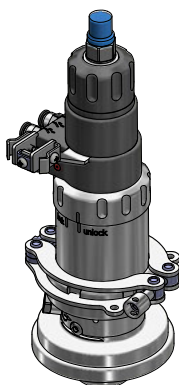

ZU1138 Retainer Clamp for SensoGate Retractable Fitting

The accessory prevents the screw joint between the retractable fitting's drive unit and the process connection from accidentally coming loose. This serves to increase safety during operation of the retractable fitting.

The retainer clamp wires connect the drive unit of the SensoGate WA131 to the coupling nut. The locking lugs on the retainer clamp engage in the grooves of the coupling nut (form-fit) and secure the screw joint.

1.6 Hazardous Substances

IN THE EVENT OF ANY CONTACT WITH HAZARDOUS SUBSTANCES OR OTHER INJURY HEREUNDER, SEEK IMMEDIATE MEDICAL ATTENTION OR FOLLOW APPLICABLE PROCEDURES TO ADDRESS HEALTH AND SAFETY OF PERSONNEL. FAILURE TO SEEK IMMEDIATE MEDICAL ATTENTION MAY RESULT IN SERIOUS INJURY OR DEATH.

In certain situations (e.g., sensor replacement or corrective maintenance), personnel may come into contact with the following hazardous substances:

- Process medium
- Calibration or cleaning medium
- Lubricant

The operating company is responsible for conducting a risk assessment.

See the relevant manufacturers' safety datasheets for hazard and safety instructions on handling hazardous substances.

1.7 Operation in Hazardous Locations

The SensoGate WA131-X is certified for operation in hazardous locations.

- EU Type Examination Certificate KEMA 04ATEX4035X

The conditions for installation and operation in explosive atmospheres can be found on the corresponding certificates.

Exceeding the standardized atmospheric conditions within the manufacturer's specifications, e.g., with regard to the ambient temperature and pressure, does not endanger the retractable fitting's durability.
→ *Specifications, p. 60*

Related certificates are included in the product's scope of delivery and are available at www.knick.de in the current version.

Observe all applicable local and national codes and standards for the installation of equipment in explosive atmospheres. For further guidance, consult the following:

- IEC 60079-14
- EU directives 2014/34/EU and 1999/92/EC (ATEX)

1.7.1 Possible Ignition Hazards During Installation and Maintenance

To avoid mechanically generated sparks, handle the SensoGate WA131-X with care and take suitable protective action, e.g., use covers and pads.

The metallic parts of the SensoGate WA131-X must be connected to the plant's equipotential bonding system using the metallic process connection and the grounding connection provided for that purpose.

When components are replaced with genuine Knick spare parts made of other materials (e.g., O-rings), the information on the nameplate may then deviate from the actual version of the SensoGate WA131-X. The operating company must assess and document the changes.

→ *Nameplates, p. 14*

Electrostatic Charging

The drive unit of specific versions of the SensoGate WA131-X contains housing components made of non-conductive plastic. Due to their surface, the housing components may build up an electrostatic charge. To prevent this charge from becoming an effective ignition source in Zone 0, ensure that the following conditions are met:

- There is no risk of highly efficient charge-generating mechanisms.
- Non-metallic components are cleaned with a moist cloth only.

Mechanically Generated Sparks

Single impacts on metal parts or collisions between metal parts of the SensoGate WA131-X are not a potential ignition source if the following conditions are met:

- Possible impact velocity is less than 1 m/s.
- Possible impact energy is less than 500 J.

If these conditions cannot be ensured, the operating company must reassess single impacts on metal parts or collisions between metal parts as potential sources of ignition. The operating company must implement suitable risk minimization measures, e.g., by ensuring a non-explosive atmosphere.

1.7.2 Possible Ignition Hazards During Operation

When using non-water-based cleaning, rinsing, or calibration media with low conductivities of less than 1 nS/m with a calibration chamber made of polypropylene (PP), electrostatic charging of internal, conductive components may occur. The operating company must assess the associated risks and take appropriate action.

The sensors that are used must be approved for operation in explosive atmospheres. Further information can be found in the sensor manufacturer's documentation.

1.8 Safety Training

Upon request, Knick Elektronische Messgeräte GmbH & Co. KG will provide safety briefings and product training during initial commissioning of the product. More information is available from the relevant local contacts.

1.9 Maintenance and Spare Parts

Preventive Maintenance

Preventive maintenance can keep the product in good condition and minimize downtimes. Knick provides recommended inspection and maintenance intervals. → *Maintenance, p. 35*

Lubricants

Only use lubricants approved by Knick. Special applications or upgrades to special lubricants are available on request. Usage of any other lubricants shall constitute an unintended use of the product.

→ *Maintenance, p. 35*

Tools and Accessory Tools

Special and accessory tools help maintenance personnel to replace components and wear parts safely and professionally. → *Tools, p. 53*

Spare Parts

For professional corrective maintenance of the product, only use Knick genuine spare parts. Usage of any other spare parts shall constitute an unintended use of the product.

→ *Spare Parts, p. 48*

Repair Service

The Knick Repair Service offers professional corrective maintenance for the product to the original quality. Upon request, a replacement unit can be obtained for the period of the repair.

Further information can be found at www.knick.de.

2 Product

2.1 Package Contents

- SensoGate WA131 in the version ordered
- User Manual
- EU Declaration of Conformity¹⁾
- EU Type Examination Certificate²⁾
- As applicable, supplementary datasheet for special versions²⁾

2.2 Product Identification

The different versions of the SensoGate WA131 are encoded in a model designation.

The model designation is stated on the nameplate, the delivery note, and the product packaging.

→ *Nameplates, p. 14*

2.2.1 Model Designation Example

Model Designation		WA131	-	X	1	A	A	H	Ø	A	A	1	1	-	Ø	Ø	V
Explosion protection	ATEX Zone 0			X										-			
Sensor	pH sensor Ø12 mm with pressurization unit, pressure chamber for compressed air supply				1									-			
Seal material	FKM					A								-			
Process-wetted materials ³⁾	1.4571/1.4404/1.4571 ⁴⁾						A							-			
Process connection	Ingold socket, 25 mm							H	Ø					-			
Immersion depth	Short									A				-			
Pneumatic connection	Without pneumatic limit signal										A			-			
Rinse media connection	Inlet G ¹ / ₈ (female), outlet G ¹ / ₈ (female) with outlet hose, complete (3 m)											1		-			
SensoLock	With												1	-			
Special version	Immersion lock for fitting without mounted sensor. For immersion depths A and K.													-	Ø	Ø	V

¹⁾ Part of package contents only for Ex-approved products

²⁾ Supplied depending on the ordered version of the SensoGate WA131 → *Product Code, p. 12*

³⁾ Material combinations: process-wetted part of calibration chamber / rinse-wetted part of calibration chamber / immersion tube

⁴⁾ Material 1.4571: alternatively 1.4404 at discretion of manufacturer

2.2.2 Product Code

Basic Unit		WA131	-	-	-	-	-	-	-	-	-	-	-	-	-	-	-
Explosion protection	ATEX Zone 0		X														
	None		N														
Sensor	Sensor, Ø 12 mm with PG 13.5		Ø														
	pH sensor Ø 12 mm with pressurization unit, pressure chamber for compressed air supply		1														
	Optical sensor, Ø 12 mm with PG 13.5		4														
Seal material	FKM		A														
	EPDM		B														
	EPDM - FDA		E														
	FKM - FDA		F														
	FFKM - FDA		H														
	FFKM Chemraz 505		J														
	FFKM		K														
	FFKM Perlast G75B		L														
	FFKM Kalrez 6375		M														
Wetted materials ¹⁾	1.4571/1.4404/1.4571 ²⁾		A														
	Hastelloy/Hastelloy/Hastelloy		B														
	PEEK/PEEK/PEEK		C														
	PVDF/PVDF/PVDF		D														
	PEEK HD/PEEK HD/PEEK HD		E														
	PVDF HD/PVDF HD/PVDF HD		F														
	PP/PP/PP		P														
	Titanium/titanium/titanium		T														
	1.4571/1.4571/PEEK		Z														
Process connection	Ingold socket, 25 mm		H	Ø													
	Flange, loose, 1.4571, PN10/16, DN 32		B	Ø													
	Flange, loose, 1.4571, PN10/16, DN 40		B	A													
	Flange, loose, 1.4571, PN10/16, DN 50		B	1													
	Flange, loose, 1.4571, PN10/16, DN 65		B	2													
	Flange, loose, 1.4571, PN10/16, DN 80		B	3													
	Flange, loose, 1.4571, PN10/16, DN 100		B	4													
	Flange, loose, 1.4571, PN40, DN 32		E	Ø													
	Flange, loose, 1.4571, PN40, DN 40		E	A													
	Flange, loose, 1.4571, PN40, DN 50		E	1													
	Flange, loose, 1.4571, PN40, DN 65		E	2													
	Flange, loose, 1.4571, PN40, DN 80		E	3													
	Flange, loose, 1.4571, PN40, DN 100		E	4													
	Dairy pipe DN 50		C	1													
	Dairy pipe DN 65		C	2													
	Dairy pipe DN 80		C	3													
	Dairy pipe DN 100		C	4													
	Flange, loose, ANSI 316, 150 lbs, 1½"		D	Ø													

¹⁾ Material combinations: process-wetted part of calibration chamber / rinse-wetted part of calibration chamber / immersion tube

²⁾ Material 1.4571: alternatively 1.4404 at discretion of manufacturer

Basic Unit	WA131	-	-	-	-	-	-	-	-	-	-	-	-	-	-
Flange, loose, ANSI 316, 150 lbs, 2"		D	1												
Flange, loose, ANSI 316, 150 lbs, 2½"		D	2												
Flange, loose, ANSI 316, 150 lbs, 3"		D	3												
Flange, loose, ANSI 316, 150 lbs, 3.5"		D	4												
Flange, loose, ANSI 316, 150 lbs, 4"		D	5												
Flange, loose, ANSI 316, 300 lbs, 1½"		P	0												
Flange, loose, ANSI 316, 300 lbs, 2"		P	1												
Flange, loose, ANSI 316, 300 lbs, 2½"		P	2												
Flange, loose, ANSI 316, 300 lbs, 3"		P	3												
G1" (male)		G	1												
G1¼" (male)		G	3												
G1½" (male)		G	5												
R1" (male) ¹⁾		R	1												
R1 ¼" (male) ¹⁾		R	3												
1"NPT (male) ¹⁾		N	1												
G2¼" for ARF210/215		K	8												
Clamp 1.5"		J	1												
Clamp 2"		J	2												
Clamp 1.5", inclined		A	J	F											
Fitting, DIN 3237-1/-2, PN16, DN 25 ²⁾		T	X												
Fitting, DIN 3237-1/-2, PN16, DN 32 ²⁾		T	0												
Fitting, DIN 3237-1/-2, PN16, DN 40 ²⁾		T	A												
Fitting, DIN 3237-1/-2, PN16, DN 50 ²⁾		T	1												
Fitting, DIN 3237-1/-2, PN16, DN 80 ²⁾		T	3												
Immersion depth	Short								A						
	Long								B						
	Short, no lock-gate function								K						
Pneumatic connection	Without pneumatic limit signal								A						
	With pneumatic limit signal								B						
Rinse media connection	Without inlet, outlet G1/8" (female) with outlet hose, complete (3 m)									0					
	Inlet G1/8" (female), outlet G1/8" (female) with outlet hose, complete (3 m)									1					
	Inlet G1/8" (female) with inlet hose, complete (5 m), outlet G1/8" (female) with outlet hose, complete (3 m)									2					
SensoLock	None										0				
	With										1				
Special version	None												0	0	0
	Equipped with special grease (provided by customer)													0	1
	With reinforced scraper ring, PTFE / PEEK (not for Ingold socket)													0	3
	Customer-specific special datasheet														F
	Immersion lock for fitting without mounted sensor. For immersion depths A, K, and pH sensor type 1.														V
	Immersion lock for fitting without mounted sensor. For sensor type 0.														W

¹⁾ For the following materials only: 1.4571, Hastelloy, titanium, PEEK

²⁾ This version requires an adapter for connection to the sight glass fitting. The adapter is part of the Knick sight glass fitting.

2.3 Nameplates

The SensoGate WA131 is identified by nameplates on the drive unit and the process unit. The information provided on the nameplates varies according to the version of the SensoGate WA131.

Nameplate, Version With Ex Approval

Note: The figure shows a nameplate for the SensoGate WA131-X version by way of example.

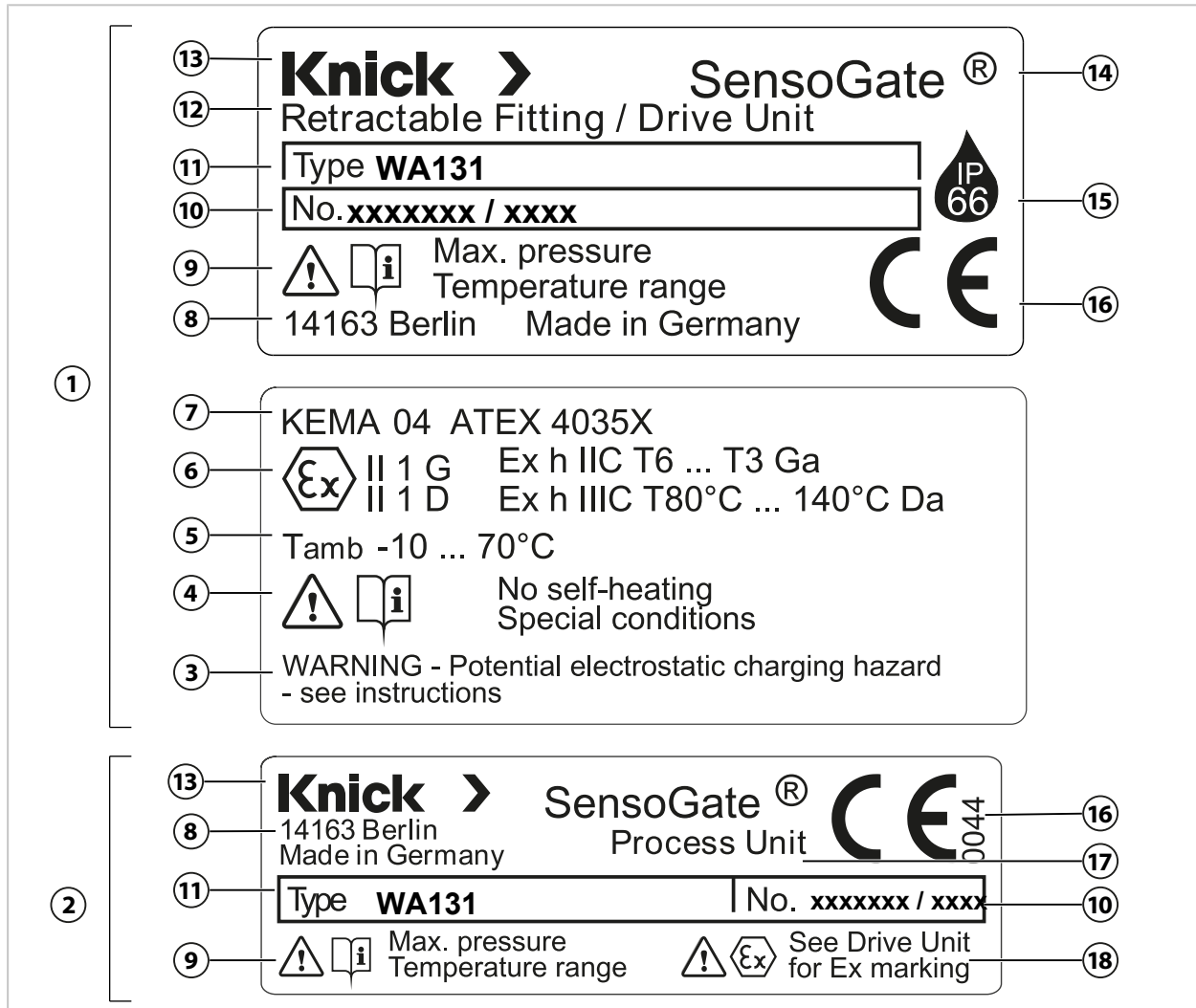

1	Drive unit nameplate	10	Serial number/production year and week YYWW
2	Process unit nameplate	11	Model designation
3	Warning: Risk of electrostatic discharge ¹⁾	12	Product group: Retractable fitting Assembly group: Drive unit
4	No self heating/special conditions ¹⁾	13	Manufacturer
5	Permissible ambient temperature	14	Product family
6	ATEX marking/information on explosion protection	15	IP degree of protection
7	EU Type Examination Certificate test number	16	CE marking with identification number
8	Manufacturer's address with designation of origin	17	Assembly group: Process unit
9	Max. operating pressure and temperature range ¹⁾	18	Drive unit ATEX information ¹⁾

¹⁾ Further information is available in the related EU Type Examination Certificate and in the → *Safety*, p. 5 and → *Specifications*, p. 60 chapters.

Nameplate, Version Without Ex Approval



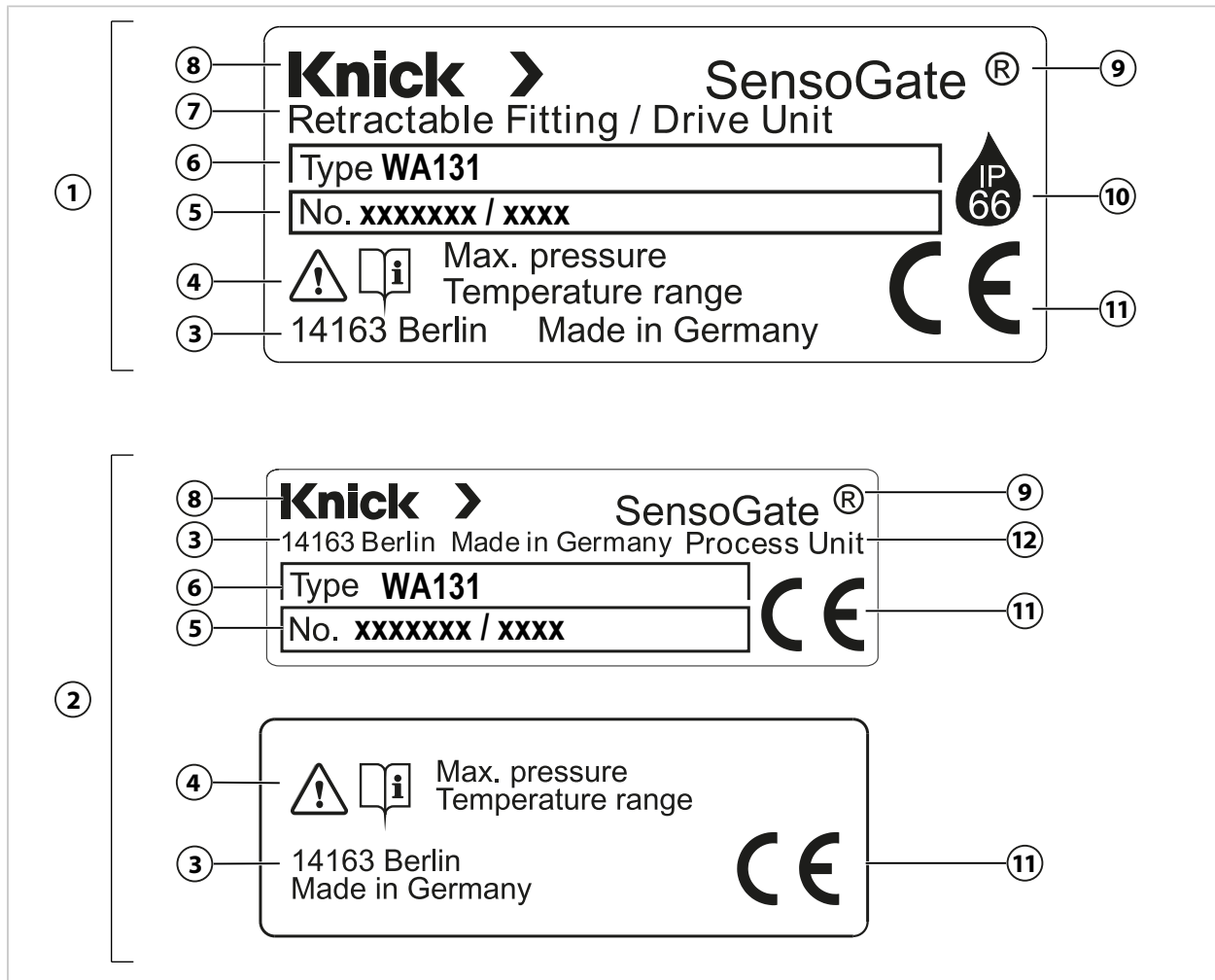







Note: The figure shows a nameplate for the SensoGate WA131-N version by way of example.



1	Drive unit nameplate	7	Product group: Retractable fitting Assembly group: Drive unit
2	Process unit nameplates	8	Manufacturer
3	Manufacturer's address with designation of origin	9	Product family
4	Max. operating pressure and temperature range ¹⁾	10	IP degree of protection
5	Serial number/production year and week YYWW	11	CE mark
6	Model designation	12	Assembly group: Process unit

¹⁾ Further information is available in the → *Safety*, p. 5 and → *Specifications*, p. 60 chapters.

2.4 Symbols and Markings

	Special conditions and danger points! Observe the safety information and instructions on safe use of the product as outlined in the product documentation.
	Reminder to read the documentation
	CE mark with identification number ¹⁾ of the notified body involved in production control
	ATEX marking ¹⁾ of the European Union for operation of SensoGate WA131-X in hazardous locations → <i>Operation in Hazardous Locations, p. 9</i>
	IP66 protection: The product is dust-tight and offers complete protection against contact as well as protection against strong water jets.
	Outlet symbol marking the outlet port of the SensoGate WA131
	Inlet symbol marking the inlet port of the SensoGate WA131 ¹⁾
	Connection of the process position (PROCESS limit position) check-back signal ¹⁾
	Connection of the service position (SERVICE limit position) check-back signal ¹⁾
	Symbol to show that the SensoGate WA131 is mechanically locked ¹⁾
	Symbol to show that the SensoGate WA131 is not mechanically locked ¹⁾

2.5 Design and Function

SensoGate WA131 consists of two main assemblies:

- Drive unit
- Process unit

The drive unit is connected to the process unit with a coupling nut. The drive unit and process unit can be separated. → *Drive Unit: Removal, p. 38*

Various different versions of drive and process unit can be combined. → *Permissible Changes, p. 19*

The process connection is used to fasten the SensoGate WA131 to the process port.

The pneumatically operated drive unit moves the SensoGate WA131 into the service position (SERVICE limit position) or the process position (PROCESS limit position). → *Service/Process Limit Positions, p. 20*

¹⁾ Dependent on the ordered version → *Product Code, p. 12*

2.5.1 Retractable Fitting

Note: The figure shows an example version of the SensoGate. → *Product Code, p. 12*

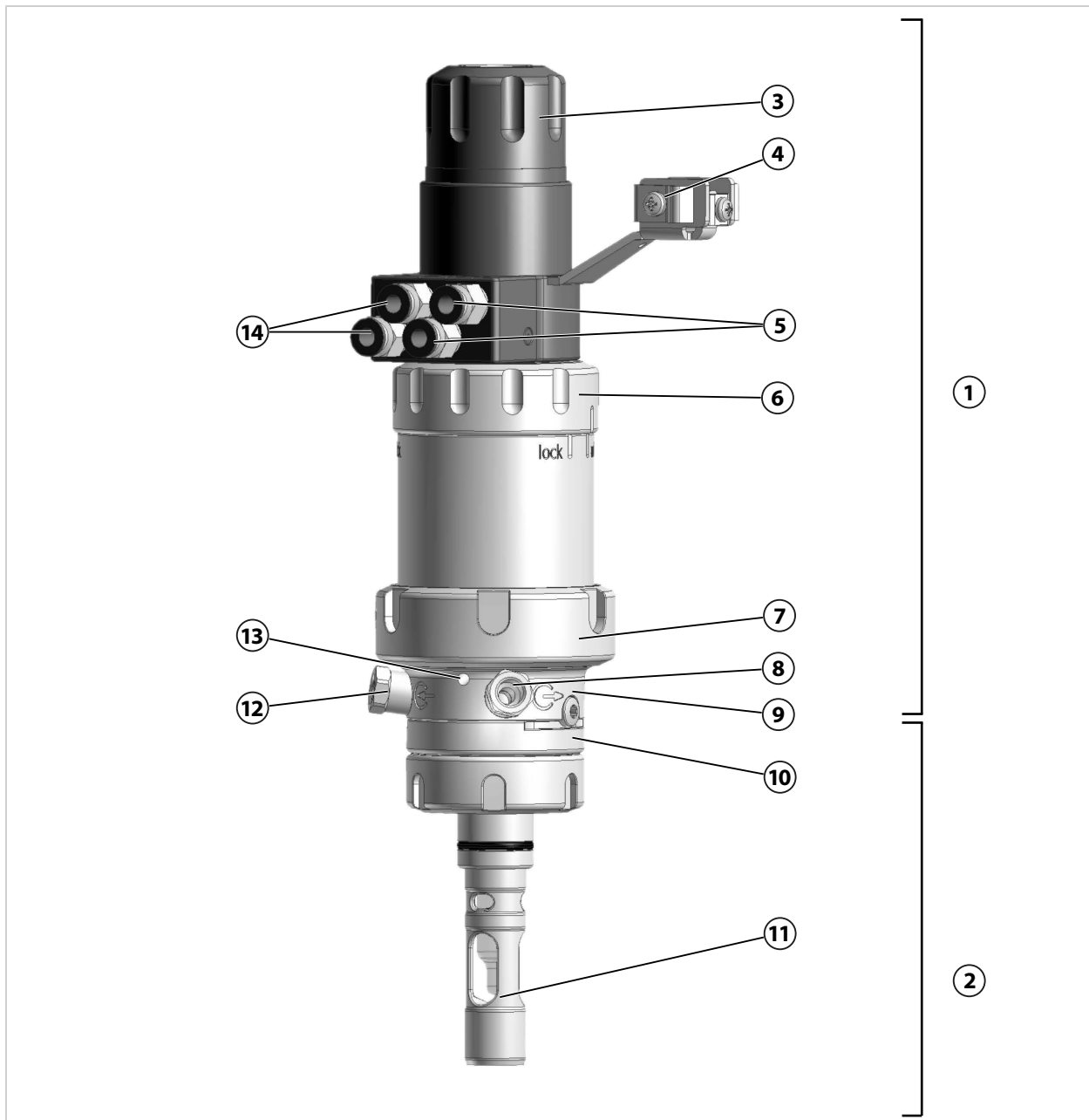

1	Drive unit	8	Outlet port
2	Process unit	9	Calibration chamber
3	Sensor holder	10	Process connection
4	Fixing bracket with grounding connection	11	Immersion tube
5	Pneumatic system check-back signal connection (option)	12	Inlet port (option)
6	SensoLock (option)	13	Leakage bore
7	Coupling nut	14	Control air connection

2.5.2 Drives and Sensor Holders

Note: The figure shows a selection from the product line. → *Product Code, p. 12*

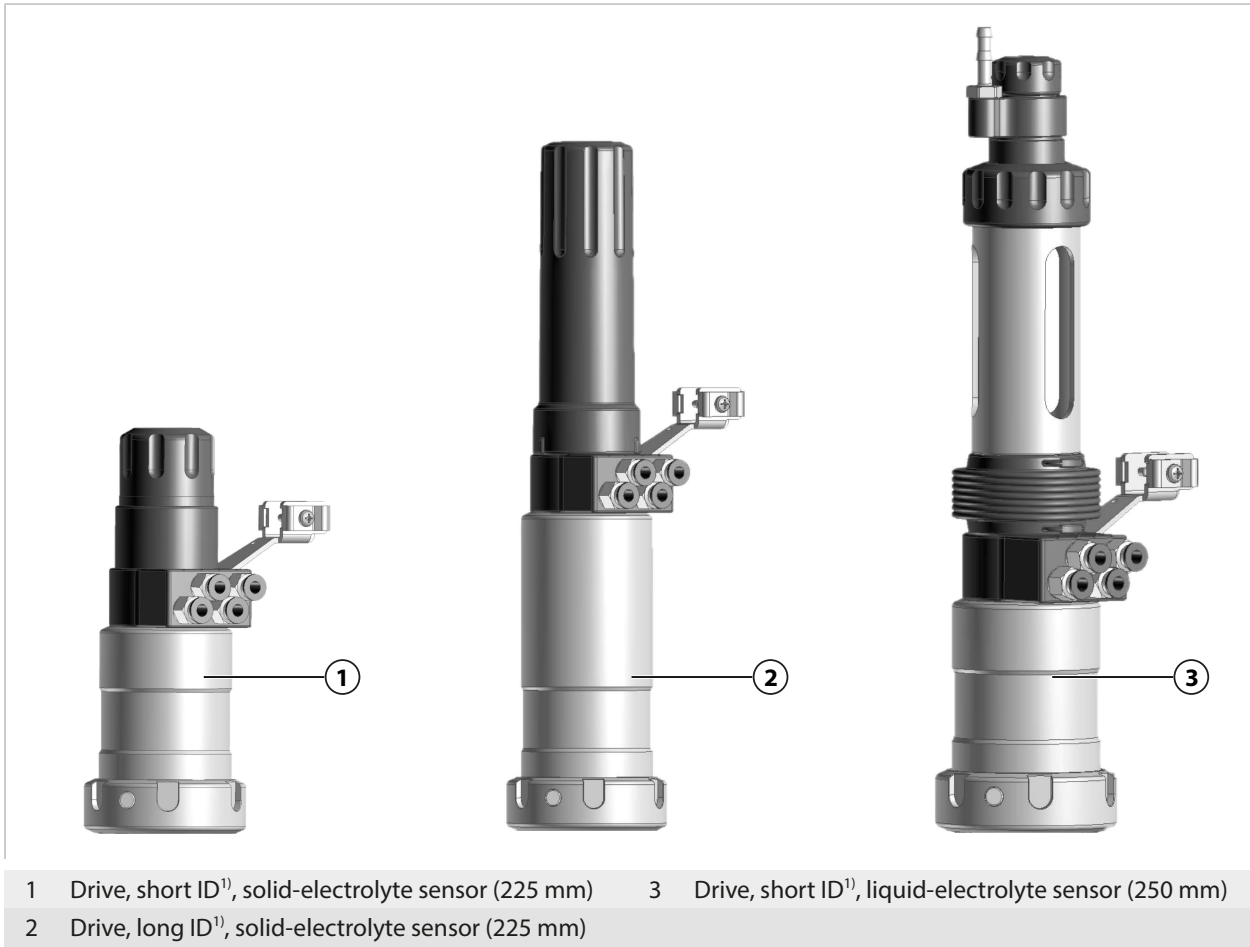

2.5.3 Process Connections

Note: The figure shows a selection from the product line. → *Product Code, p. 12*

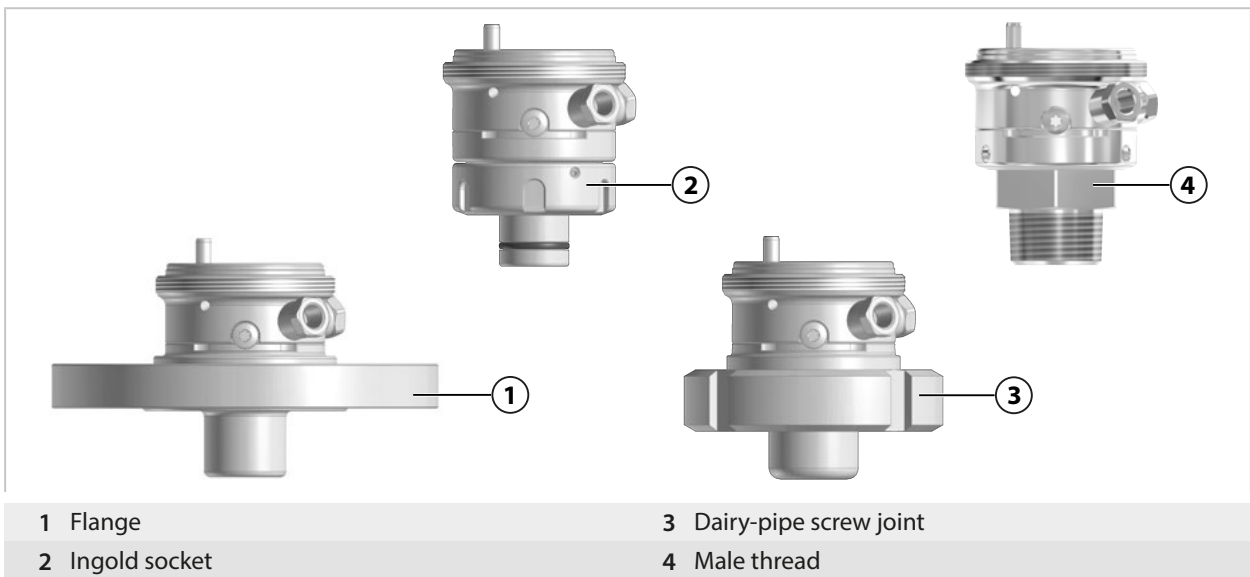

¹⁾ ID = immersion depth

2.5.4 Immersion Tubes

Note: The figure shows a selection from the product line. → *Product Code, p. 12*

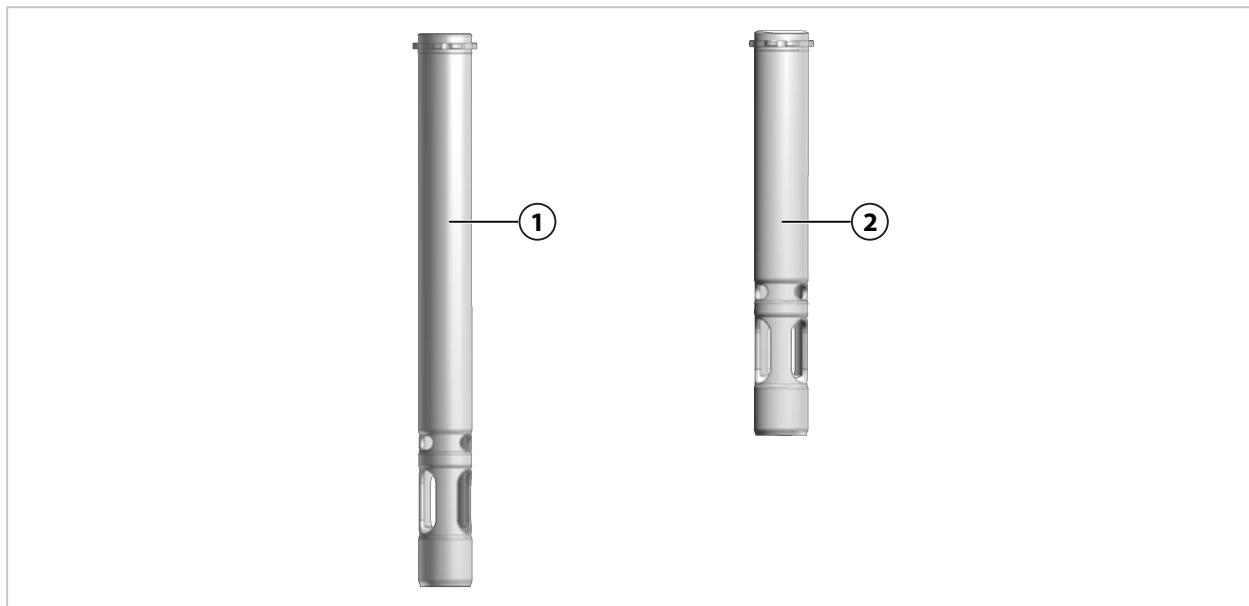

1 Immersion tube, long (204 mm)
Materials: 1.4571 (1.4404)¹⁾, PEEK, PVDF, Hastelloy,
and optionally titanium → *Spare Parts, p. 48*

2 Immersion tube, short (149 mm)
Materials: 1.4571 (1.4404)¹⁾, PEEK, PVDF, Hastelloy,
and optionally titanium → *Spare Parts, p. 48*

2.6 Permissible Changes

The SensoGate WA131 can be adapted to changed conditions by the customer. Prior to making any changes, contact Knick Elektronische Messgeräte GmbH & Co. KG. The following are examples of possible changes:

- Change to a different process connection → *Process Connections, p. 18*
- Modification of the sensor holder to fit another sensor type → *Drives and Sensor Holders, p. 18*
- Replacement of process-wetted components (calibration chamber, immersion tube, seals) with other material characteristics → *Maintenance, p. 35*
- Retrofit of safeguards, e.g., "Immersion Lock Without a Mounted Liquid-Electrolyte Sensor" → *Safeguards, p. 6*

Any changes may result in deviations between the information on the nameplate and the actual version of the SensoGate WA131. The operating company must assess and document the changes. In the event of a change to the version, the product must be identified accordingly.

It is recommended that changes to the SensoGate WA131 be carried out by the Knick Repair Service. After making the necessary changes, a functional and pressure test is carried out and, if necessary, a modified nameplate is attached. → *Knick Repair Service, p. 43*

More information on changes can be found in the related supplementary datasheet. Maintenance instructions with detailed instructions for action are available on request.

¹⁾ Material 1.4571: alternatively 1.4404 at discretion of manufacturer

2.7 Service/Process Limit Positions

2.7.1 Service and Process Position

The SensoGate WA131 can assume two limit positions (service or process positions).

Note: The SensoGate WA131 is only disconnected from the process in the service position (SERVICE limit position). This is *not* the case in any other position, i.e., there remains contact with the process.

Service Position (SERVICE Limit Position)

- The sensor is not in contact with the process medium.
- The sensor can be installed, removed, and, as necessary, cleaned while the process is running.¹⁾
- The measuring system can be calibrated and adjusted.¹⁾
- The limit position can be pneumatically monitored.¹⁾

Process Position (PROCESS Limit Position)

- The sensor is in contact with the process medium.
- The desired process parameters can be measured.
- The limit position can be pneumatically monitored.¹⁾

The service position (SERVICE limit position) and process position (PROCESS limit position) are indicated in different ways depending on the version of the SensoGate WA131.

Solid-electrolyte sensor, short immersion depth	Solid-electrolyte sensor, long immersion depth	Liquid-electrolyte sensor, short immersion depth
--	---	---

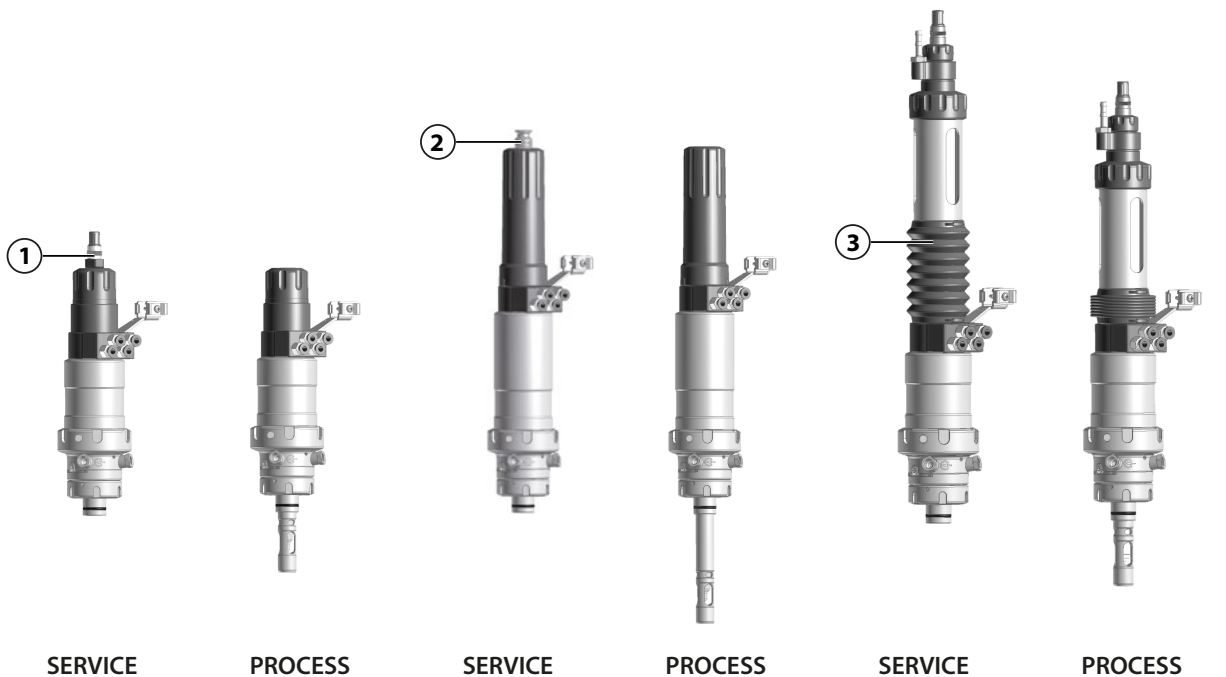

SERVICE **PROCESS**

In the service position, the sensor head **(1)** is visible at the top end of the protection sleeve.

In the process position, the sensor head **(1)** is retracted into the protection sleeve.

SERVICE **PROCESS**

In the service position, the service cap **(2)** is visible at the top end of the extension.

In the process position, the service cap **(2)** is retracted into the extension.

SERVICE **PROCESS**

In the service position, the bellows **(3)** are expanded.

In the process position, the bellows **(3)** are compressed.

¹⁾ Availability of functions depends on the ordered version. → *Product Code*, p. 12

2.7.2 Limit Signals

On versions of the SensoGate WA131 with pneumatic limit signal, a pneumatic signal is applied to the corresponding push-in connection when a limit position is reached. This signal can either be processed directly or converted into an electrical signal through use of a limit switch (ZU0859).

→ *Accessories, p. 49*

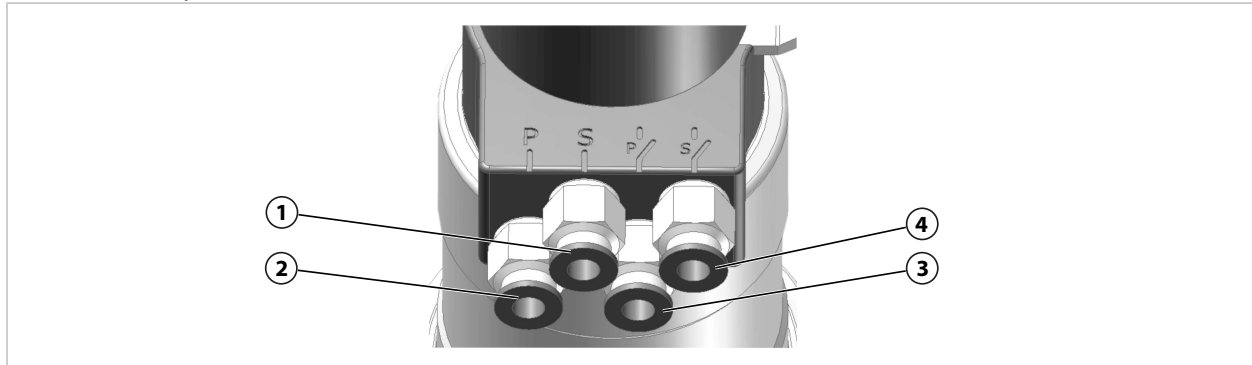

1	SERVICE compressed air connection	3	PROCESS limit position compressed air connection
2	PROCESS compressed air connection	4	SERVICE limit position compressed air connection

3 Installation

3.1 Retractable Fitting: Installation

⚠ WARNING! Risk of explosion from mechanically generated sparks when used in explosive atmospheres. Take appropriate action to prevent mechanically generated sparks. Follow the safety instructions. → *Operation in Hazardous Locations, p. 9*

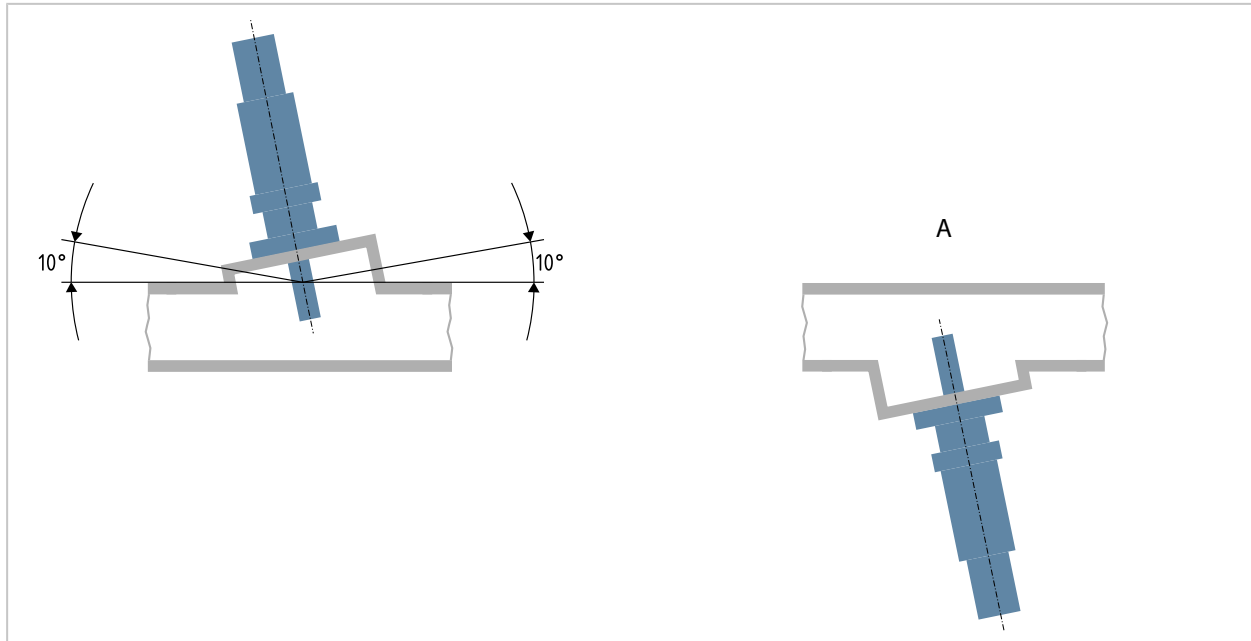

01. Check the package contents of the SensoGate WA131 for completeness. → *Package Contents, p. 11*
02. Check the SensoGate WA131 for damage.
03. Ensure the required sensor installation clearances. → *Dimension Drawings, p. 54*
Note: The installation angle of the SensoGate WA131 depends on the sensor type. An installation angle of up to 10° above the horizontal plane is permissible for all sensor types. An installation angle upside down (see view A) is only permitted if using sensors approved for upside-down operation.
04. Fasten the SensoGate WA131 to the process port using the process connection.
05. Optional: If using the product in explosive atmospheres, connect the grounding connection of the SensoGate WA131 to the plant's equipotential bonding system.

See also

→ *Operation in Hazardous Locations, p. 9*

→ *Commissioning, p. 26*

3.2 Safety Accessories: Installation

Consult the related instructions for information on installing the safety accessories (e.g., ZU0818 retainer clamp).

See also

→ *Safety Accessories, p. 8*

3.3 Outlet Hose: Installation

Note: The outlet is used to discharge rinse medium and trapped process medium and must not be closed. Installation of the supplied drain hose is also recommended for versions without a rinse connection. By moving the sensor to the service/process limit positions, pressurized process medium can enter the calibration chamber and be compressed when the outlet is closed. This process medium may splash out during sensor replacement.

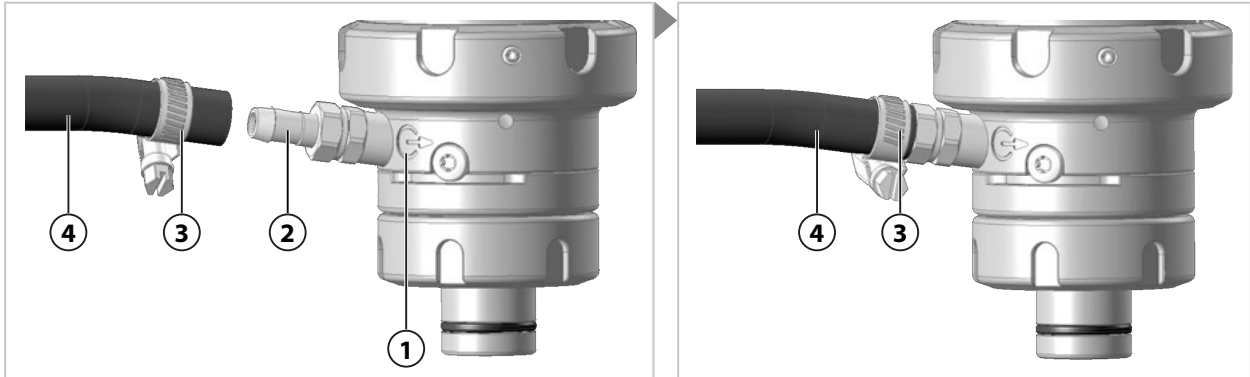

Note: The symbol (1) designates the outlet.

01. Push the hose clamp (3) onto the outlet hose (4).
02. Completely push the outlet hose (4) onto the connection nozzle (2).
03. Secure the outlet hose (4) with the hose clamp (3).

Upside-Down Installation

If installing the SensoGate WA131 upside down, lay the outlet hose in an arc above the level of the calibration chamber. This prevents gravity from causing the calibration chamber to leak.

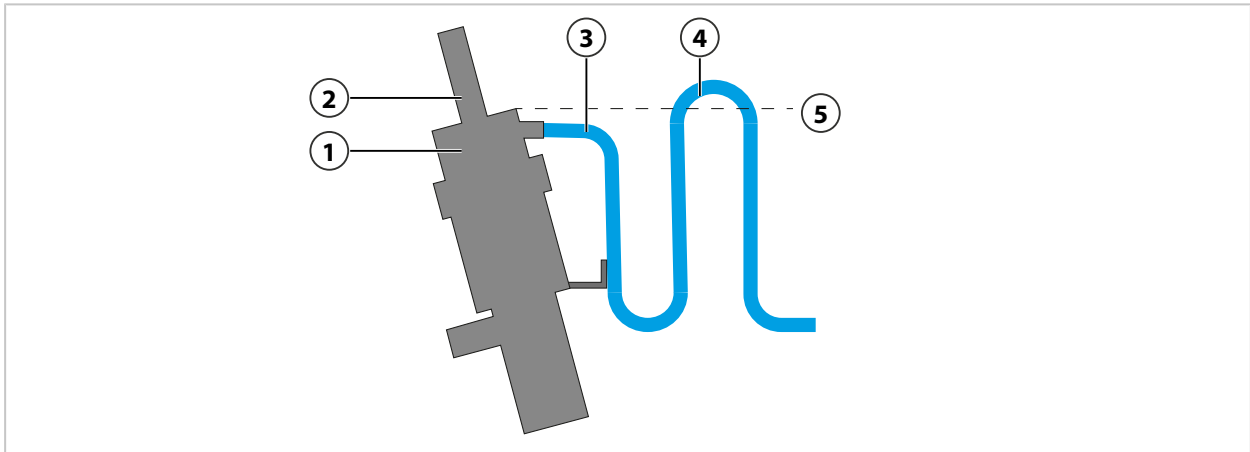

1 Calibration chamber	4 Hose arc
2 Sensor	5 Calibration chamber level
3 Outlet hose	

3.4 Inlet Hose (Option): Installation

NOTICE! Drinking water may be contaminated by rinse and process media when connecting to drinking water pipes. Observe the information contained in EN 1717. Install a suitable check valve (e.g., check valve RV01) at the water or rinse connection. → *Accessories, p. 49*

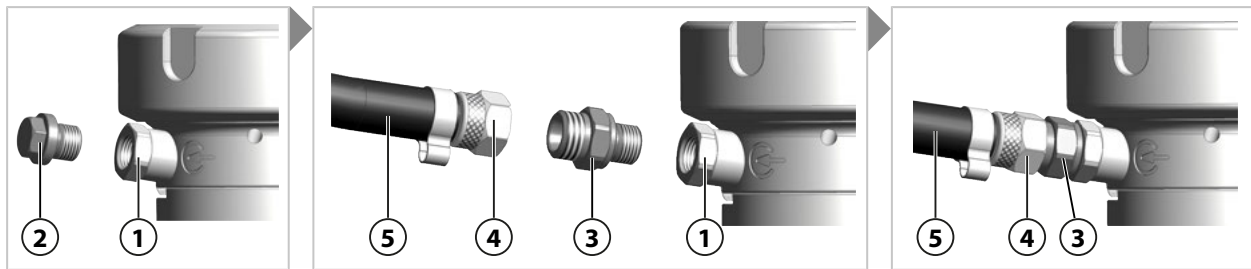

Note: When using versions of the SensoGate WA131 with inlet port, the sealing insert or the inlet hose¹⁾ must be installed at the inlet for safe operation. As delivered, the inlet port is sealed with a sealing insert. → *Product Code, p. 12*

01. To install the inlet hose (5), unscrew the sealing insert (2) from the inlet port (1).
02. Screw the coupling (3), part of the inlet hose (5), into the inlet port (1).
03. Fasten the inlet hose (5) with coupling nut (4) to the coupling (3).

3.5 Pneumatic Control: Installation

With the SensoGate WA131 retractable fitting, movements to the service position (SERVICE limit position) or the process position (PROCESS limit position) are pneumatically controlled.

Installation Without Pneumatic Limit Signal²⁾

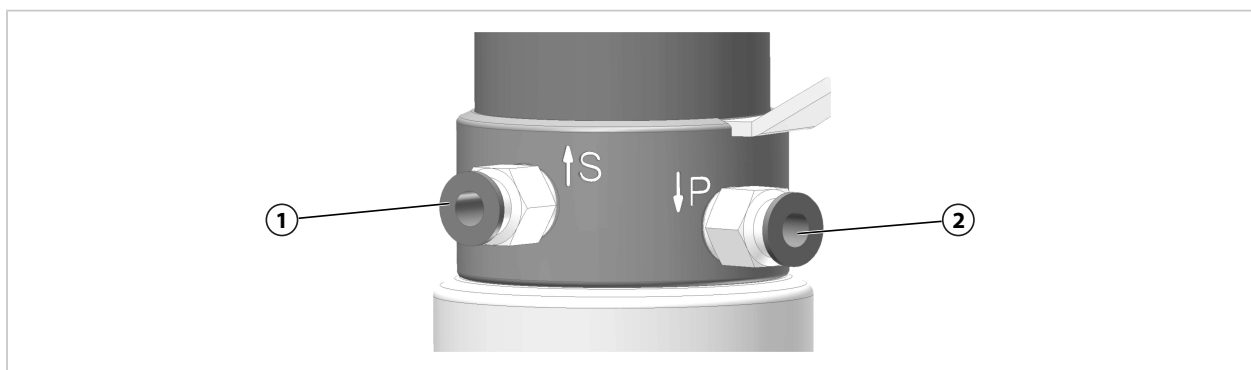

01. Push the compressed air hose DN 6 fully into the Service connector (1).
02. Push the compressed air hose DN 6 fully into the Process connector (2).

¹⁾ Availability dependent on the ordered version → *Product Code, p. 12*

²⁾ Availability dependent on the ordered version → *Product Code, p. 12*

Installation With Pneumatic Limit Signal¹⁾

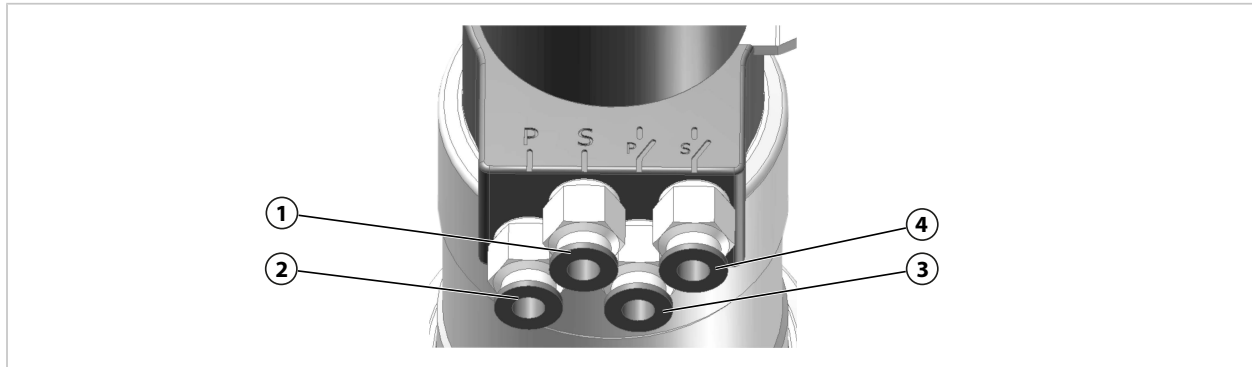

01. Push the compressed air hose DN 6 fully into the Service connector **(1)**.
02. Push the compressed air hose DN 6 fully into the Process connector **(2)**.
03. Push the compressed air hose DN 6 fully into the Service check-back connector **(4)**.
04. Push the compressed air hose DN 6 fully into the Process check-back connector **(3)**.

3.6 Protective Pane Option: Installation

Note: A flange protector (ZU0595, ZU0596, ZU0597, or ZU0598) **(3)** is required to protect the flange DN 80 or DN 100 **(1)** from aggressive media. → *Accessories, p. 49*

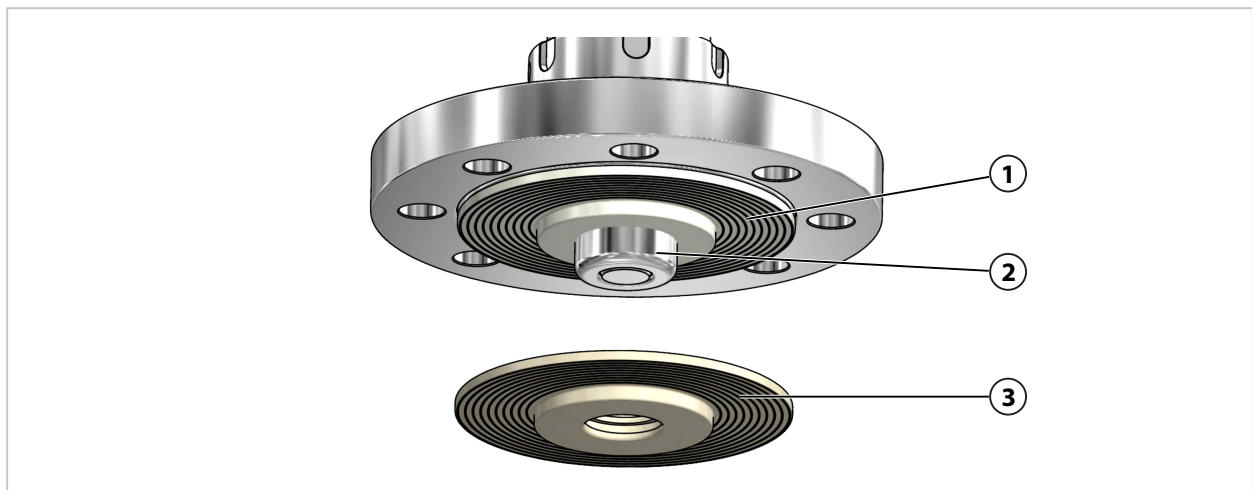

01. Push the protective pane **(3)** over the sensor housing **(2)**.
02. Fully cover the flange surface **(1)**.

¹⁾ Availability dependent on the ordered version → *Product Code, p. 12*

4 Commissioning

▲ WARNING! If the SensoGate WA131 fitting is damaged or improperly installed, process medium, potentially containing hazardous substances, may escape. Follow the safety instructions.
→ *Safety, p. 5*

Note: Upon request, Knick will provide safety briefings and product training during initial commissioning of the product. More information is available from the relevant local contacts.

01. Install the SensoGate WA131. → *Retractable Fitting: Installation, p. 22*
 02. Install the outlet hose. → *Outlet Hose: Installation, p. 23*
 03. Install the connections for the pneumatic control. → *Pneumatic Control: Installation, p. 24*
 04. As required, install the inlet hose¹⁾. → *Inlet Hose (Option): Installation, p. 24*
 05. As required, install the flange protector¹⁾. → *Protective Pane Option: Installation, p. 25*
 06. Mount the sensor. → *Installing and Removing Sensors, p. 28*
 07. Ensure that the process connection is securely fastened.
 08. Optional: Ensure that installed safety accessories (e.g., ZU0818 retainer clamp) are securely fastened. → *Safety Accessories, p. 8*
 09. Optional: Ensure that the SensoGate WA131-X is correctly connected to the plant's equipotential bonding system. → *Operation in Hazardous Locations, p. 9*
 10. Move the SensoGate WA131 into the process position (PROCESS limit position).
→ *Moving into the Process Position (PROCESS Limit Position), p. 27*
✓ Sensor head/service cap is not visible.
 11. Move the SensoGate WA131 into the service position (SERVICE limit position).
→ *Moving into the Service Position (SERVICE Limit Position), p. 27*.
✓ Sensor head/service cap visible.
 12. Check the SensoGate WA131 for leaks under process conditions.
Note: Pressure and leak tests must be carried out in accordance with the relevant operating regulations or the operating company's instructions.
✓ There are no leaks in the SensoGate WA131 or its connections.
- ✓ SensoGate WA131 is ready for operation.

¹⁾ Dependent on the ordered version → *Product Code, p. 12*

5 Operation

5.1 Moving into the Process Position (PROCESS Limit Position)

⚠ WARNING! Process medium, potentially containing hazardous substances, may escape from the SensoGate WA131. Only move the SensoGate WA131 into the process position (PROCESS limit position) if a sensor is installed. → *Installing and Removing Sensors, p. 28*

⚠ CAUTION! Risk of crushing injuries to hands and fingers. When moving to the limit positions, the SensoGate WA131 with liquid-electrolyte sensor performs a stroke movement (approx. 43 mm). Do not touch the SensoGate WA131 while it is moving to the limit positions.

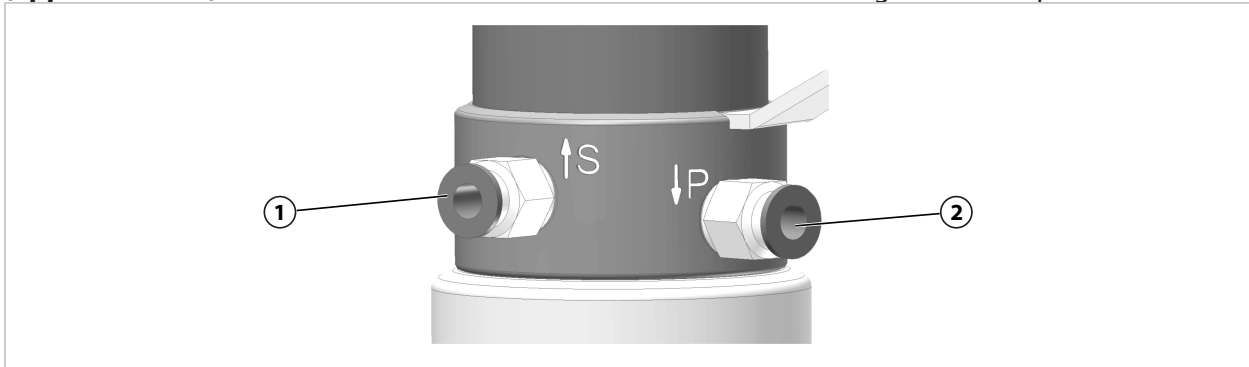

01. Install the sensor. → *Installing and Removing Sensors, p. 28*

Note: When moving to the process position (PROCESS limit position), the control air **(1)** is vented and the process air **(2)** is pressurized.

02. Move the SensoGate WA131 into the process position (PROCESS limit position).

✓ Sensor head/service cap is not visible.

5.2 Moving into the Service Position (SERVICE Limit Position)

⚠ CAUTION! Risk of crushing injuries to hands and fingers. When moving to the limit positions, the SensoGate WA131 with liquid-electrolyte sensor performs a stroke movement (approx. 43 mm). Do not touch the SensoGate WA131 while it is moving to the limit positions.

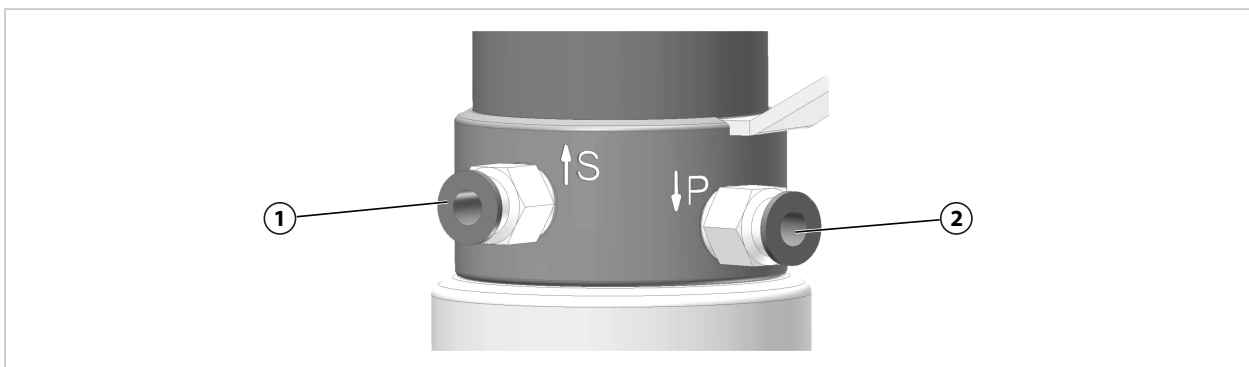

Note: When moving to the service position (SERVICE limit position), the control air **(1)** is pressurized and the process air **(2)** is vented.

01. Move the SensoGate WA131 into the service position (SERVICE limit position).

✓ Sensor head/service cap is visible.

5.3 Installing and Removing Sensors

5.3.1 Safety Instructions on Installing and Removing Sensors

⚠ WARNING! Process medium, potentially containing hazardous substances, may escape from the SensoGate WA131. Follow the safety instructions. → *Safety, p. 5*

⚠ CAUTION! Risk of cutting injuries from broken sensor glass. Handle the sensor with care. Follow the safety instructions in the sensor manufacturer's documentation.

Note: The outlet is used to discharge trapped rinse medium and must not be closed. By moving the SensoGate WA131 to the limit positions, pressurized process medium may enter the calibration chamber. When the outlet is closed, this process medium may be compressed and splash out during a sensor replacement. → *Design and Function, p. 16*

5.3.2 Solid-Electrolyte Sensor, Short Immersion Depth: Installation

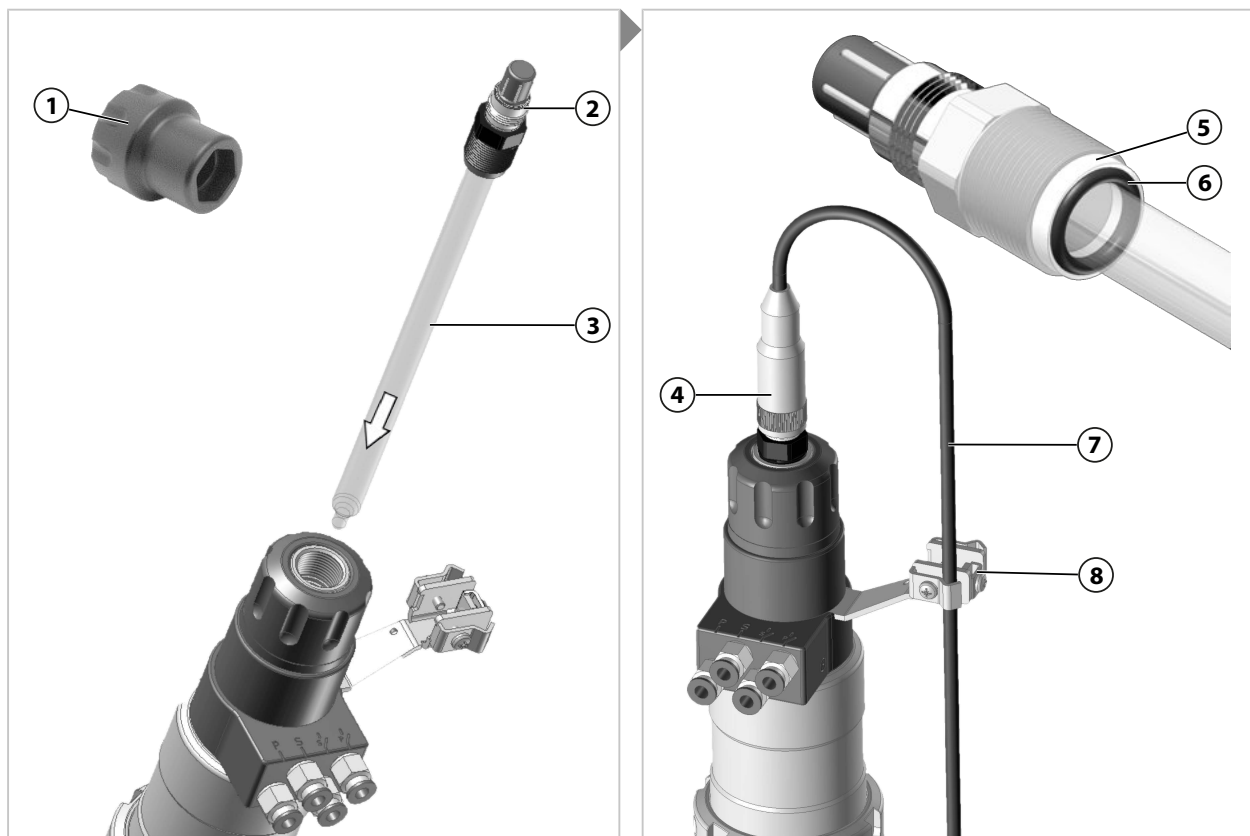

01. Move the SensoGate WA131 into the service position (SERVICE limit position).
→ *Moving into the Service Position (SERVICE Limit Position), p. 27.*
02. Check outlet and leakage bores for escaping process medium. If process medium escapes: Stop the process (depressurize if necessary) and perform troubleshooting. → *Troubleshooting, p. 44*
03. Optional: Set SensoLock to "lock".
04. Check the washer (5) and O-ring (6) of the sensor (3) for correct positioning and damage, and replace them if necessary.
05. Push the sensor (3) into the SensoGate WA131.
06. Tighten the sensor (3) using the spanning wrench (1) to max. 3 Nm (A/F 19 mm). Recommended tool: ZU0647 sensor spanning wrench → *Tools, p. 53*
Note: When tightening the sensor, the spring force of the "Immersion Lock Without a Mounted Solid-Electrolyte Sensor" safeguard must be overcome.
07. Connect the cable bushing (4) to the sensor head (2).

08. On first-time installation: Hold the sensor cable **(7)** in a loop and fasten it with the clamp **(8)**.
During this process, the sensor cable loop must be long enough so that the sensor cable does not impede the stroke movement of the SensoGate WA131.
09. On first-time installation: Optionally, connect the equipotential bonding cable to the clamp **(8)**.
10. Optional: Install the ZU0759/1 protective cap. → *Accessories, p. 49*
11. Optional: Set SensoLock to “unlock”.

✓ The sensor is installed.

5.3.3 Solid-Electrolyte Sensor, Short Immersion Depth: Removal

Note: Rinse the sensor prior to removal in order to prevent entrainment of chemically aggressive process medium in the area of the sensor holders.

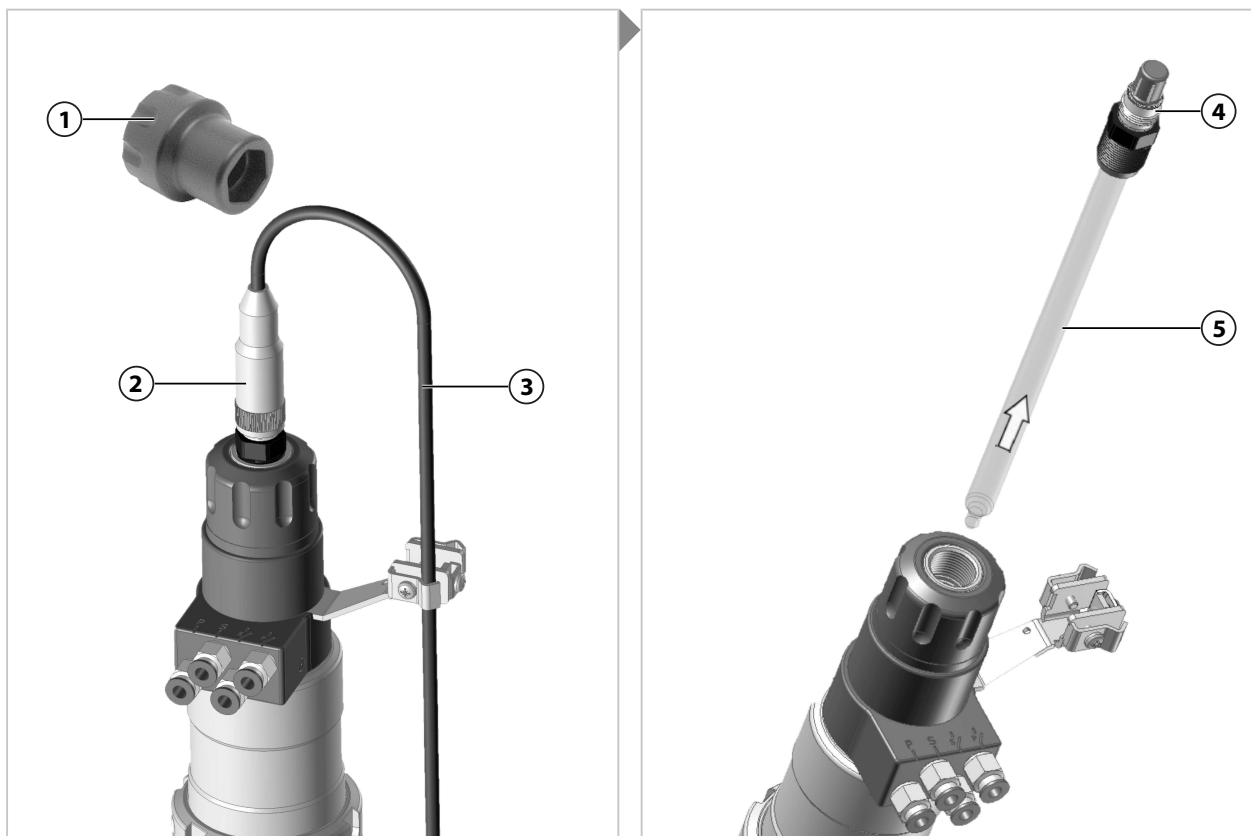

01. Move the SensoGate WA131 into the service position (SERVICE limit position).
→ *Moving into the Service Position (SERVICE Limit Position), p. 27.*
02. Check outlet and leakage bores for escaping process medium. If process medium escapes: Stop the process (depressurize if necessary) and perform troubleshooting. → *Troubleshooting, p. 44*
03. Optional: Remove the ZU0759 protective cap.
04. Optional: Set SensoLock to “lock”.
05. Disconnect the cable bushing **(2)** of the sensor cable **(3)** from the sensor head **(4)**.
06. Release the sensor **(5)** using the spanning wrench **(1)** (A/F 19 mm). Recommended tool: ZU0647 sensor spanning wrench. → *Tools, p. 53*
07. Pull out the sensor **(5)**.
08. If the sensor glass is broken, check the immersion tube seal for damage and replace it if necessary. → *Immersion Tube: Removal, p. 40*

✓ The sensor is removed.

5.3.4 Solid-Electrolyte Sensor, Long Immersion Depth: Installation

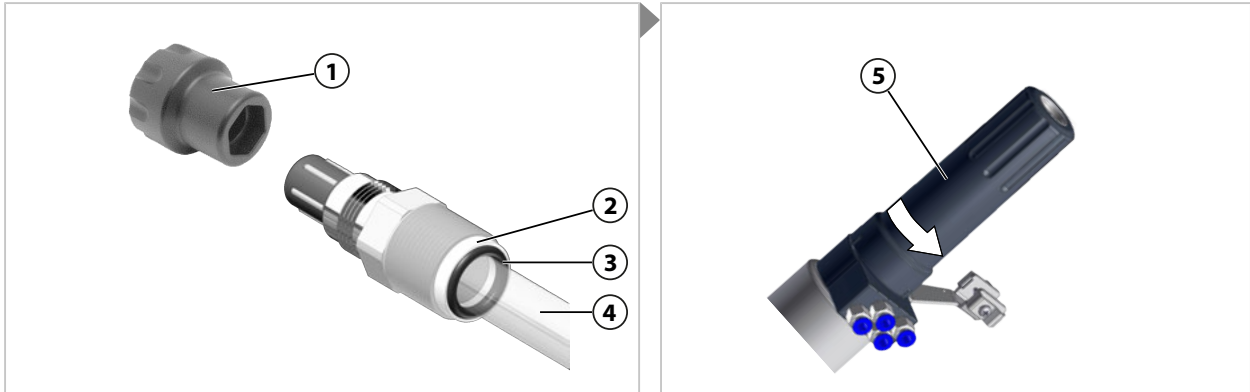

01. Move the SensoGate WA131 into the service position (SERVICE limit position).
→ *Moving into the Service Position (SERVICE Limit Position), p. 27.*
02. Check outlet and leakage bores for escaping process medium. If process medium escapes: Stop the process (depressurize if necessary) and perform troubleshooting. → *Troubleshooting, p. 44*
03. Optional: Set SensoLock to "lock".
04. Check the washer (2) and O-ring (3) of the sensor (4) for correct positioning and damage, and replace them if necessary.
05. Rotate the extension (5) counterclockwise until its bayonet coupling opens.
06. Remove the extension (5).

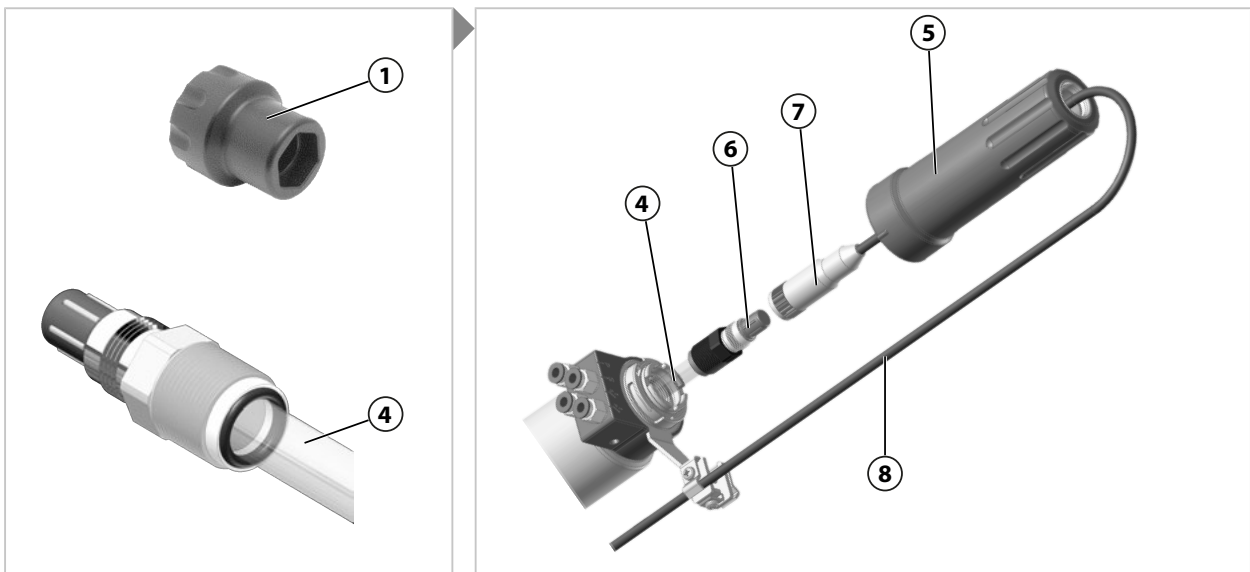

07. Push in the sensor (4).
08. Tighten the sensor (4) using the spanning wrench (1) to max. 3 Nm (A/F 19 mm). Recommended tool: ZU0647 sensor spanning wrench → *Tools, p. 53*
09. On first-time installation: Remove the split red service cap (9) from the extension (5). Keep the service cap (9) in a safe place for future use.
10. On first-time installation: Guide the cable bushing (7) through the extension (5).
11. Connect the cable bushing (7) to the sensor head (6).

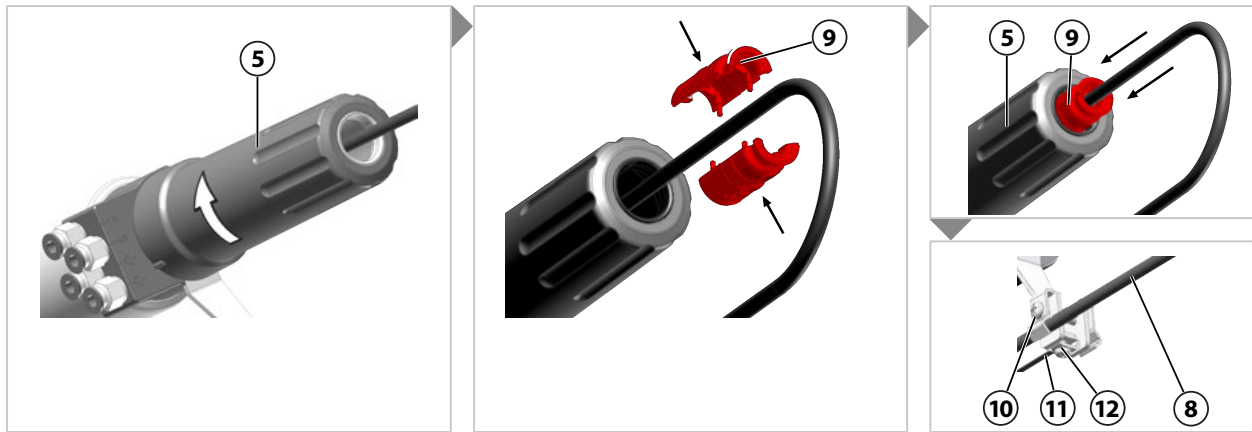

12. Position the extension **(5)** and rotate clockwise until the bayonet coupling engages.
13. On first-time installation: Mount the two-part red service cap **(9)** on the sensor cable **(8)** above the extension **(5)**.
14. On first-time installation: Push the service cap **(9)** toward the extension **(5)** until the service cap **(9)** positively engages.
15. On first-time installation: Hold the sensor cable **(8)** in a loop and fasten it with the clamp **(10)**. During this process, the sensor cable loop must be long enough so that the sensor cable does not impede the stroke movement of the SensoGate WA131.
16. On first-time installation: Connect the equipotential bonding cable **(11)** to the terminal **(12)**.
17. Optional: Install the ZU0759/1 protective cap. → *Accessories, p. 49*
18. Optional: Set SensoLock to “unlock”.

✓ The sensor is installed.

5.3.5 Solid-Electrolyte Sensor, Long Immersion Depth: Removal

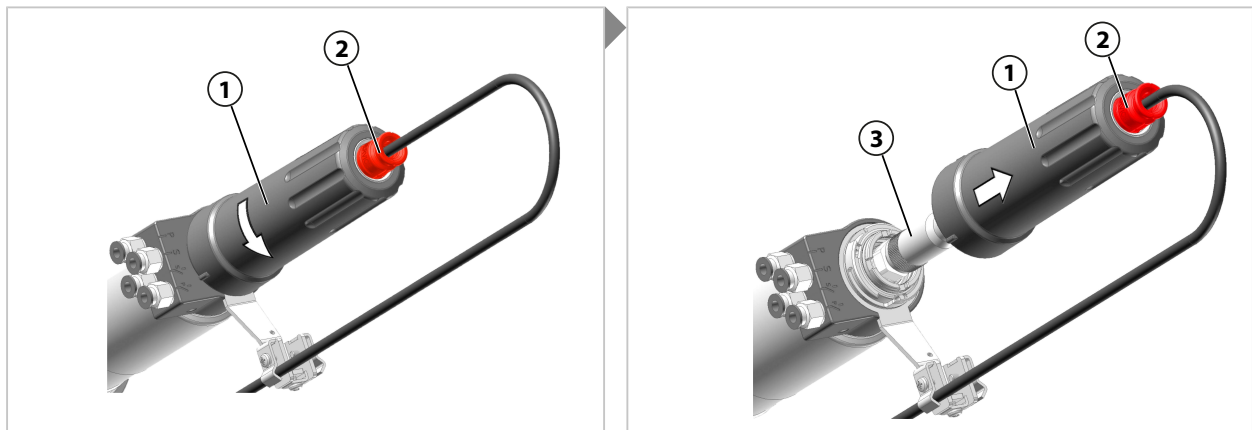

01. Move the SensoGate WA131 into the service position (SERVICE limit position).
→ *Moving into the Service Position (SERVICE Limit Position), p. 27.*
02. Check outlet and leakage bores for escaping process medium. If process medium escapes: Stop the process (depressurize if necessary) and perform troubleshooting. → *Troubleshooting, p. 44*
03. Optional: Remove the ZU0759 protective cap.
04. Optional: Set SensoLock to “lock”.
05. Rotate the extension **(1)** counterclockwise until its bayonet coupling opens.
Note: The extension can only be unlocked in the service position (SERVICE limit position). The red service cap **(2)** must be visible in order to unlock. → *Service/Process Limit Positions, p. 20*
06. Pull off the extension **(1)** until the cable bushing **(3)** is accessible.

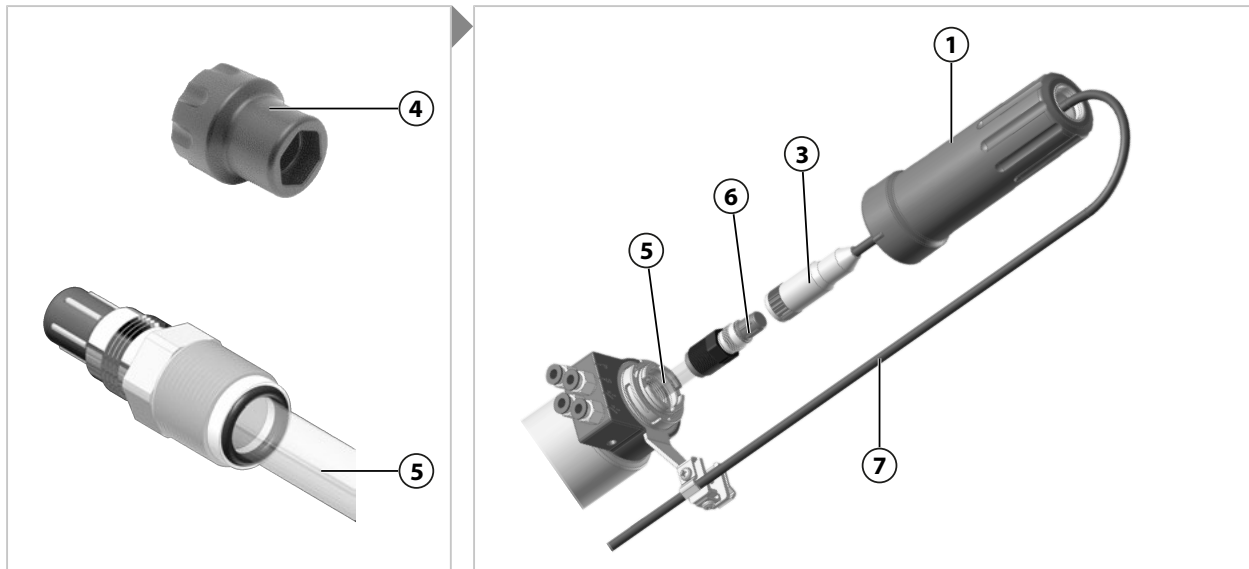

07. Disconnect the cable bushing **(3)** of the sensor cable **(7)** from the sensor head **(6)**.
08. Release the sensor **(5)** using the spanning wrench **(4)** (A/F 19 mm). Recommended tool: ZU0647 sensor spanning wrench → *Tools, p. 53*
09. Pull out the sensor **(5)**.
10. If the sensor glass is broken, check the immersion tube seal for damage and replace it if necessary. → *Immersion Tube: Removal, p. 40*

✓ The sensor is removed.

5.3.6 Liquid-Electrolyte Sensor: Installation

Note: To ensure that the electrolyte flows from the reference electrode to the process medium, the air pressure in the pressure chamber must be 0.5 to 1 bar above that of the process medium.

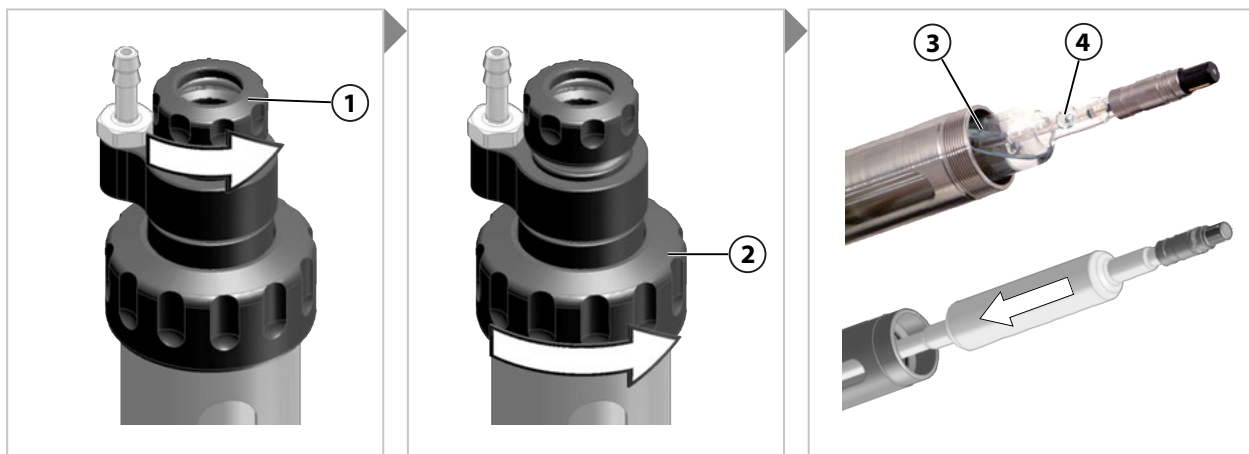

01. Move the SensoGate WA131 into the service position (SERVICE limit position).
→ *Moving into the Service Position (SERVICE Limit Position), p. 27.*
02. Check outlet and leakage bores for escaping process medium. If process medium escapes: Stop the process (depressurize if necessary) and perform troubleshooting. → *Troubleshooting, p. 44*
03. Optional: Set SensoLock to "lock".
04. Loosen the small coupling nut **(1)** by a few rotations; do not loosen completely.
05. Fully loosen the large coupling nut **(2)** and pull off the entire unit.
06. Remove the watering cap from the sensor tip and rinse the sensor **(3)** with water.
07. Remove the cap of the filling hole **(4)** of the sensor **(3)**.

08. Push in the sensor **(3)**.

Note: In the case of inclined installation, turn the electrolyte filling hole towards the top to prevent electrolyte from flowing out during operation of the SensoGate WA131. Observe any deviating direction of installation specified by the sensor manufacturer.

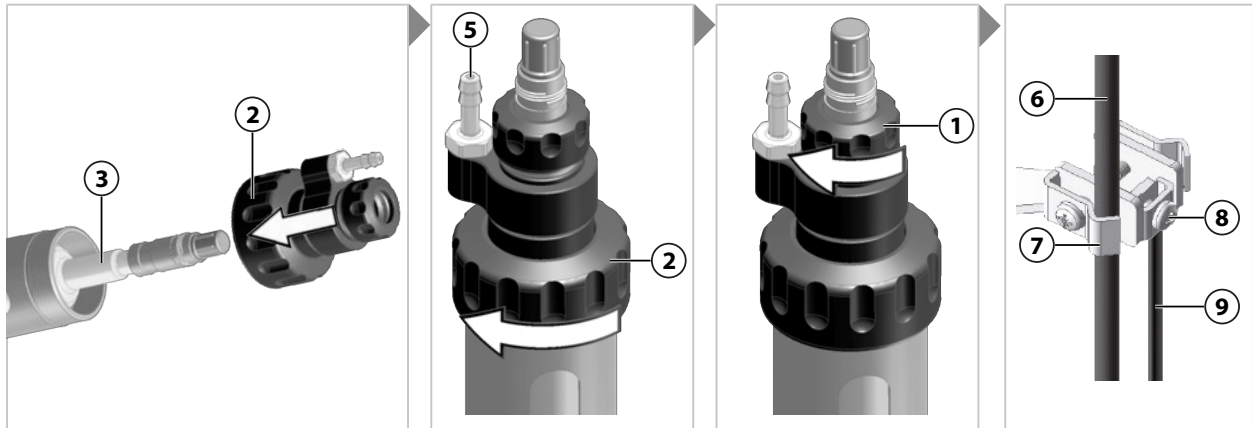

09. Position the large coupling nut **(2)** and fasten finger tight.

10. Fasten the small coupling nut **(1)** finger tight.

11. Connect the sensor cable **(6)**.

12. On first-time installation: Hold the sensor cable **(6)** in a loop and fasten it with the clamp **(7)**. During this process, the sensor cable loop must be long enough so that the sensor cable does not impede the stroke movement of the SensoGate WA131.

13. On first-time installation: Connect the air pressure inlet for the pressure chamber to the connection nozzle **(5)**.

14. On first-time installation: Connect the equipotential bonding cable **(9)** to the clamp **(8)**.

15. Optional: Set SensoLock to "unlock".

✓ The sensor is installed.

5.3.7 Liquid-Electrolyte Sensor: Removal

Note: Rinse the sensor prior to removal in order to prevent entrainment of chemically aggressive process medium in the area of the sensor holders.

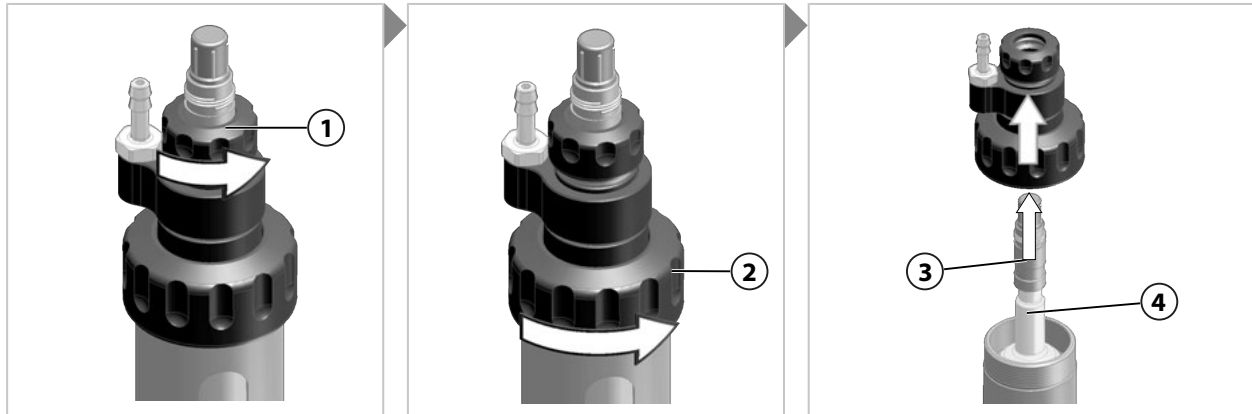

01. Move the SensoGate WA131 into the service position (SERVICE limit position).
→ *Moving into the Service Position (SERVICE Limit Position), p. 27.*
 02. Check outlet and leakage bores for escaping process medium. If process medium escapes: Stop the process (depressurize if necessary) and perform troubleshooting. → *Troubleshooting, p. 44*
 03. Optional: Set SensoLock to "lock".
 04. Disconnect the sensor cable.
 05. Loosen the small coupling nut **(1)** by a few rotations; do not loosen completely.
 06. Fully loosen the large coupling nut **(2)** and pull off the entire unit.
 07. Pull out the sensor **(3)**.
Note: Hold the sensor's filling hole **(4)** upward at an inclined angle during removal to prevent electrolyte from escaping. Follow the instructions in the sensor manufacturer's documentation. During transport and storage, close the sensor's filling hole with the cap.
 08. If the sensor glass is broken, check the immersion tube seal for damage and replace it if necessary. → *Immersion Tube: Removal, p. 40*
- ✓ The sensor is removed.

6 Maintenance

6.1 Inspection

6.1.1 Inspection and Maintenance Intervals

NOTICE! Different process conditions (e.g., pressure, temperature, chemically aggressive media) will affect the inspection and maintenance intervals. Analyze the specific application and process conditions at hand. Define appropriate intervals based on similar application cases where experience has already been gained.

Interval ¹⁾	Work Required
First inspection after a few days/ weeks	Move the SensoGate WA131 into the service position (SERVICE limit position). If the product is not tight, process medium will escape from the outlet hose. → <i>Moving into the Service Position (SERVICE Limit Position)</i> , p. 27 As necessary, replace process-wetted (dynamically loaded) O-rings. → <i>Seal Kits</i> , p. 46 <hr/> Check leakage bores for process deposits. → <i>Safeguards</i> , p. 6 As necessary, replace process-wetted (dynamically loaded) O-rings. → <i>Seal Kits</i> , p. 46
After 6 ... 12 months ²⁾	Repeat the measures implemented during the first inspection.
After 5,000 ... 10,000 strokes	As necessary, replace process-wetted (dynamically loaded) O-rings. → <i>Seal Kits</i> , p. 46
After approx. 2 years	In particular if using chemically aggressive cleaning agents, check the rinse-wetted O-rings and replace them if necessary. → <i>Seal Kits</i> , p. 46
After approx. 5 years	Service the drive, replace O-rings, and re-grease. → <i>Corrective Maintenance</i> , p. 38

6.1.2 Immersion Lock Without a Mounted Solid-Electrolyte Sensor: Functional Test

To check the function of the immersion lock, the situation of a missing sensor is simulated.

Note: The functional test is possible only on a SensoGate WA131 with the corresponding safeguard.
→ *Safeguards*, p. 6

01. Move the SensoGate WA131 into the service position (SERVICE limit position).
→ *Moving into the Service Position (SERVICE Limit Position)*, p. 27.

02. Optional: Set SensoLock to “unlock”.

03. Loosen the sensor a maximum of 1.5 turns.

NOTICE! In the event of a malfunction, pressurized process medium, potentially containing hazardous substances, may escape from the SensoGate WA131. Loosen the sensor no more than a maximum of 1.5 turns to ensure that pressure resistance is still available in the event of a malfunction.

04. Move the SensoGate WA131 into the process position (PROCESS limit position).
→ *Moving into the Process Position (PROCESS Limit Position)*, p. 27

✓ The SensoGate WA131 does not move to the process position (PROCESS limit position).

05. Fully screw in and tighten the sensor. Tightening torque 1 ... 3 Nm:

06. Repeat the functional test every 12 months. As applicable, adjust the interval to match the specific application for which the SensoGate WA131 is used.

¹⁾ The stated intervals are general recommendations based on Knick’s experience. The actual intervals are dependent on the specific application for which the SensoGate WA131 is used.

²⁾ Following successful first inspection and confirmation of the suitability of all materials used, the interval may be lengthened.

6.1.3 Immersion Lock Without a Mounted Liquid-Electrolyte Sensor: Functional Test

To check the function of the immersion lock, the situation of a missing sensor is simulated.

Note: The functional test is only available for a SensoGate WA131 with the safeguard "Immersion Lock Without a Mounted Liquid-Electrolyte Sensor". The safeguard can be seen at the yellow indicator ring **(2)** above the bellows **(1)**. → *Safeguards, p. 6*

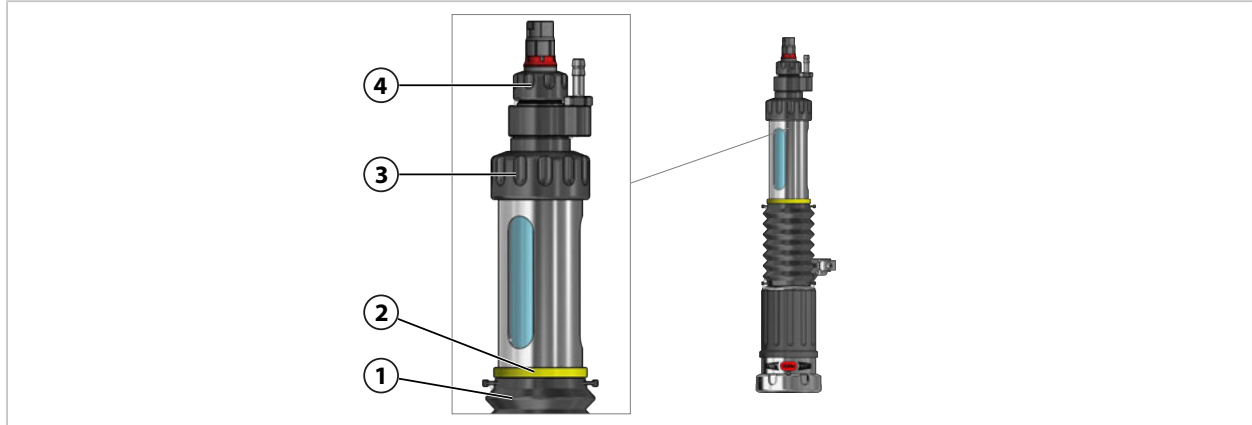

01. Move the SensoGate WA131 into the service position (SERVICE limit position).

→ *Moving into the Service Position (SERVICE Limit Position), p. 27.*

02. Optional: Set SensoLock to "unlock".

03. Loosen but do not remove the small coupling nut **(4)**.

04. Loosen the large coupling nut **(3)** by around 1.5 turns.

⚠ WARNING! In the event of a malfunction, pressurized process medium may escape from the SensoGate WA131. Do not completely loosen the large coupling nut **(3)** to ensure that pressure resistance is still available in the event of a malfunction.

05. Move the SensoGate WA131 into the process position (PROCESS limit position).

→ *Moving into the Process Position (PROCESS Limit Position), p. 27*

✓ The process position (PROCESS limit position) of the SensoGate WA131 is locked.

06. Tighten the coupling nuts **(3)** and **(4)**.

07. Repeat the functional test every 12 months. As applicable, adjust the interval to match the specific application for which the SensoGate WA131 is used.

6.2 Preventive Maintenance

6.2.1 Approved Lubricants

Application	Pharma and Food		Chemicals and Wastewater
Lubricant	Beruglide L ¹⁾ (silicone-free)	Paraliq GTE 703 ²⁾ (containing silicone)	Syntheso Glep 1 (silicone-free)
Elastomer seal materials			
FKM	-	-	+
FFKM	-	-	+
EPDM	-	-	+
FKM – FDA	+	+	-
FFKM – FDA	+	+	-
EPDM – FDA	+	+	-

Note: Lubricant Paraliq GTE 703 contains silicone and has good lubricating properties even at elevated temperatures and with numerous travel movements. Paraliq GTE 703 is used as a special version at the customer’s express request.

6.2.2 Characteristics of Process-Wetted Materials

Note: The stated values are reference values and provide general information. Concentrations of acids or alkalis, temperatures, mechanical effects, and the duration of the effect impact the materials to a greater or lesser degree. Therefore, no guarantee is given for the stated values. A pretest is recommended for cases where there has been no prior experience using the material in the process. Mixtures of substances constitute a prime example.

	Mechanical strength	Temperature resistance	Resistance to acids	Resistance to alkalis	Resistance to salt solutions	Resistance to cleaning agents or solvents
Stainless steel material no. 1.4571	1	1	3 ³⁾	2	3	2
Hastelloy C-22 material no. 2.4602	1	1	2	1	1	1
PEEK (carbon fiber-reinforced)	1	1	2 ⁴⁾	1	1	2
PVDF (carbon fiber-reinforced)	2	2	2 ⁵⁾	2	1	2
PP (carbon fiber-reinforced)	3	4 ⁶⁾	3 ⁷⁾	3	2	2
Titanium Grade 2 material no. 3.7035	1	1	2	1	1	1
1 = very well suited					5 = unsuitable	

See also

→ *Product Code*, p. 12

1) FDA compliant, NSF-H1 registered

2) FDA compliant, USDA-H1 registered

3) Not resistant to hydrochloric or sulfuric acid

4) Not resistant to highly oxidizing media (concentrated sulfuric acid, nitric acid, or hydrogen fluoride)

5) Not resistant to ketones, amines, fuming sulfuric and nitric acid

6) Max. 80 °C (176 °F)

7) Not resistant to highly oxidizing media (e.g., nitric acid, chromic acid, or halogens)

6.3 Corrective Maintenance

6.3.1 Corrective Maintenance Safety Instructions

⚠ WARNING! Process medium, potentially containing hazardous substances, may escape from the SensoGate WA131. Follow the safety instructions. → *Safety, p. 5*

⚠ CAUTION! Risk of cutting injuries from broken sensor glass. Handle the sensor with care. Follow the safety instructions in the sensor manufacturer's documentation.

6.3.2 Drive Unit: Removal

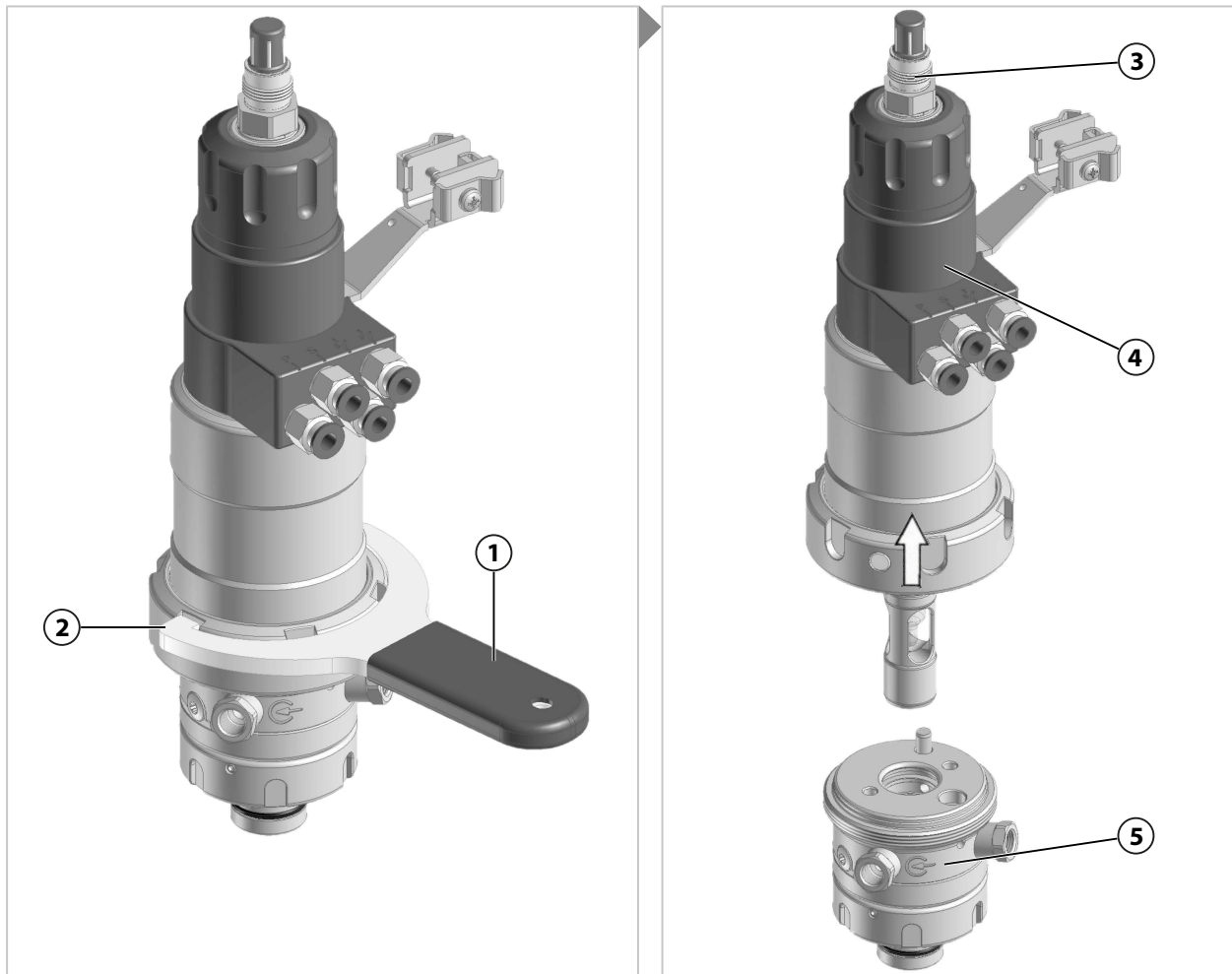

01. Safely disconnect the SensoGate WA131 from the process. → *Retractable Fitting: Removal, p. 45*
 02. As required, disconnect the outlet and inlet hoses¹⁾.
 03. Move the SensoGate WA131 into the service position (SERVICE limit position).
→ *Moving into the Service Position (SERVICE Limit Position), p. 27.*
 04. As necessary, remove the sensor (3). → *Installing and Removing Sensors, p. 28*
 05. Using the spanning wrench (1), loosen the coupling nut (2) counterclockwise.
Note: Do not tilt the coupling nut. Use a suitable spanning wrench (e.g., the one contained in ZU0680 service set or ZU0740 service set). → *Tools, p. 53*
 06. Pull the drive unit (4) out of the process unit (5).
- ✓ The drive unit is removed.

¹⁾ Dependent on the ordered version → *Product Code, p. 12*

6.3.3 Drive Unit: Assembly

Note: The radial installation position of the drive unit is determined by a coding pin in the calibration chamber and a hole in the drive unit. The coupling nut can be tightened only if the drive unit is correctly inserted into the process unit.

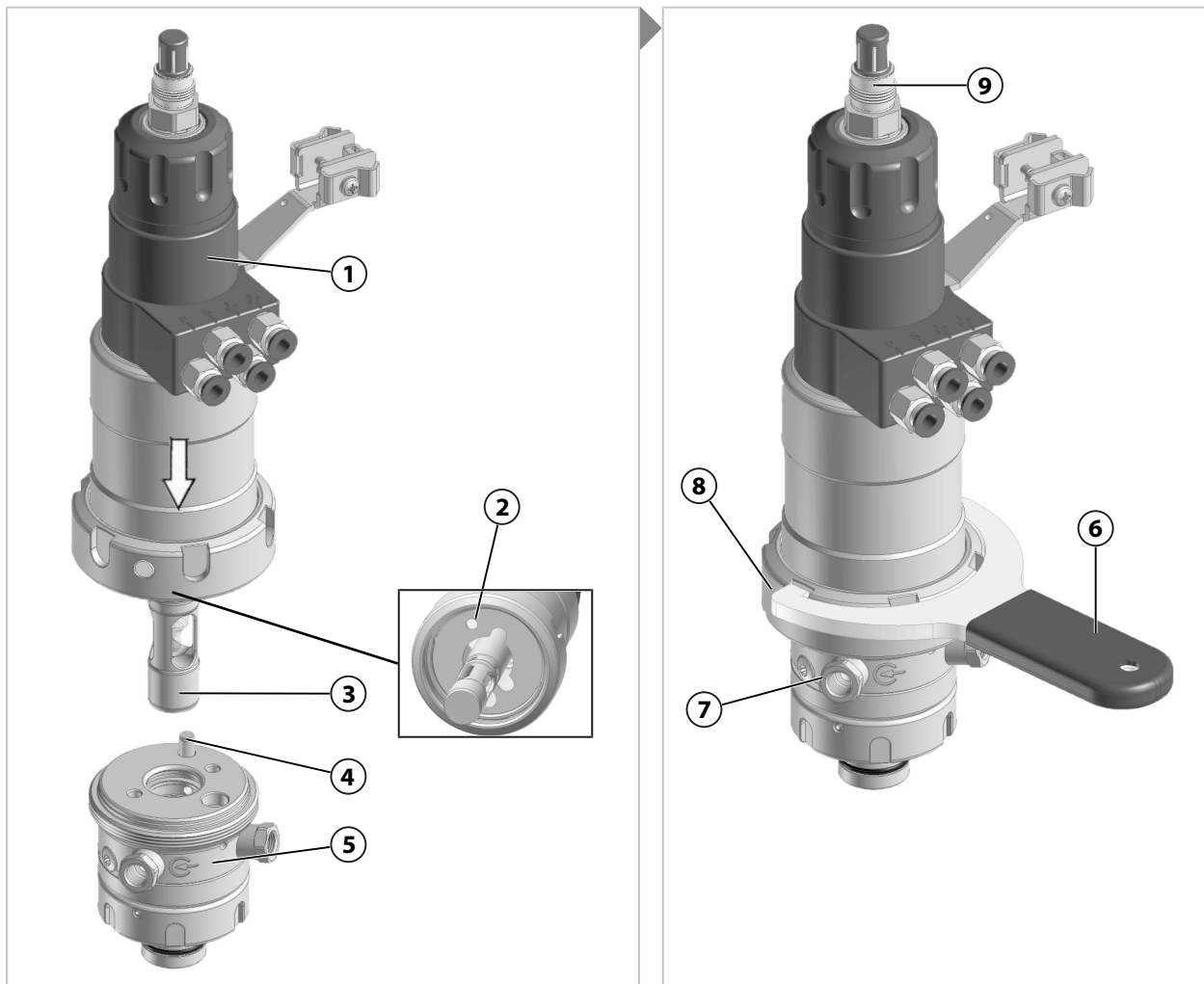

01. Move the drive unit to the service position (SERVICE limit position).
→ *Moving into the Service Position (SERVICE Limit Position)*, p. 27
 02. Push the drive unit (1) with the immersion tube (3) into the process unit (5). While doing so, position the coding pin (4) in the hole (2).
 03. Position the coupling nut (8) and tighten clockwise finger tight or to approx. 10 Nm using the spanning wrench (6).
Note: Do not tilt the coupling nut. Use a suitable spanning wrench (e.g., the one contained in ZU0680 service set or ZU0740 service set). → *Tools*, p. 53
 04. As required, install the outlet hose at the outlet (7). → *Outlet Hose: Installation*, p. 23
 05. As required, install the inlet hose¹⁾. → *Inlet Hose (Option): Installation*, p. 24
 06. As required, install the sensor (9). → *Installing and Removing Sensors*, p. 28
- ✓ The drive unit is installed.

¹⁾ Dependent on the ordered version → *Product Code*, p. 12

6.3.4 Immersion Tube: Removal

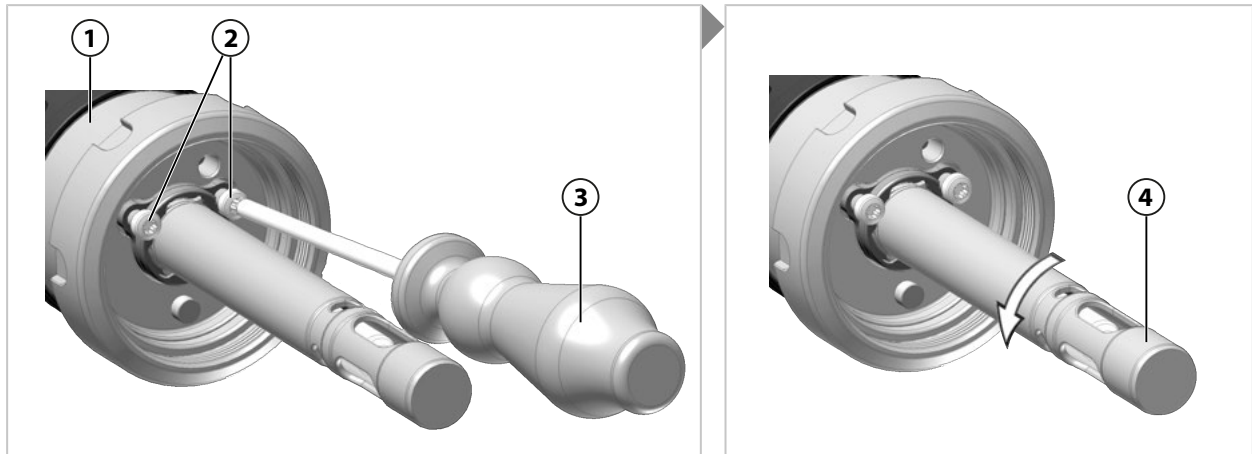

01. Remove the drive unit **(1)**. → *Drive Unit: Removal, p. 38*
02. Optional: Set SensoLock to “unlock”.
03. Pull the immersion tube **(4)** until the process position (PROCESS limit position) is reached.
04. Loosen the screws **(2)** around 4 rotations using a screwdriver of type TX25 **(3)** (do not completely unscrew).
05. Rotate the immersion tube **(4)** around 60° counterclockwise until the bayonet coupling of the immersion tube **(4)** is open.

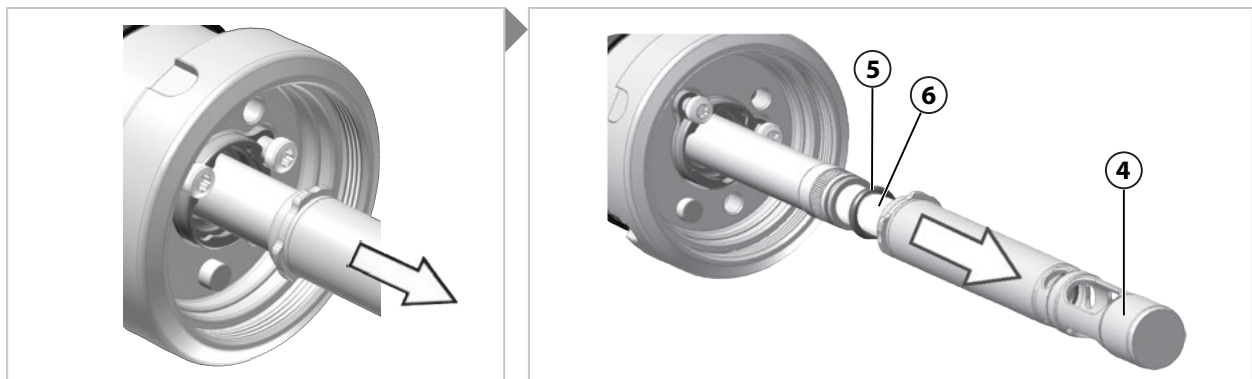

06. Pull the immersion tube **(4)** off the sensor **(6)**.
 ✓ The O-ring **(5)** is now visible, or it may be located in the removed immersion tube **(4)**.
07. Check the O-ring **(5)** for damage; replace the O-ring **(5)** if necessary. → *Seal Kits, p. 46*
 ✓ The immersion tube is removed.

6.3.5 Immersion Tube: Installation

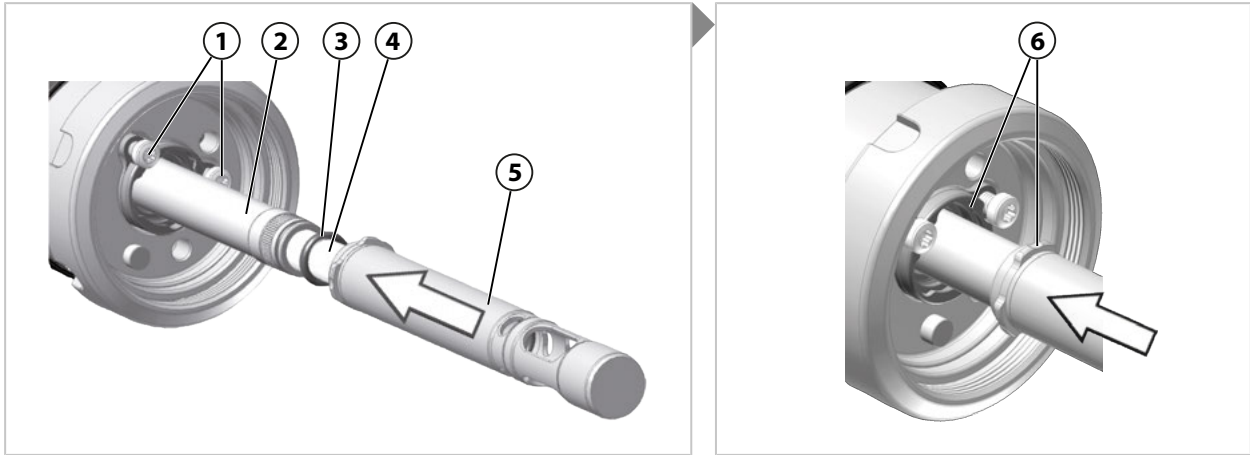

01. Install the sensor (4). → *Installing and Removing Sensors, p. 28*
02. If the drive unit is not in process position (PROCESS limit position): Firmly push the immersion tube (5) into the sensor protection (6), at the same time rotating around 60° clockwise up to the hard stop.
Pull the immersion tube (5) until the process position (PROCESS limit position) is reached.
03. Check the O-ring (3) for damage; replace the O-ring (3) if necessary. → *Seal Kits, p. 46*
04. Push the O-ring (3) fully onto the sensor (4).
05. If the screws (1) were not loosened during removal, loosen them around 4 rotations now using a screwdriver of type TX25 (7) (do not completely unscrew).
06. Carefully push the immersion tube (5) onto the sensor (4) and insert it into the bayonet coupling (6).
Note: There may be an O-ring in the immersion tube left over from the removal process. Remove this O-ring from the immersion tube prior to installation.

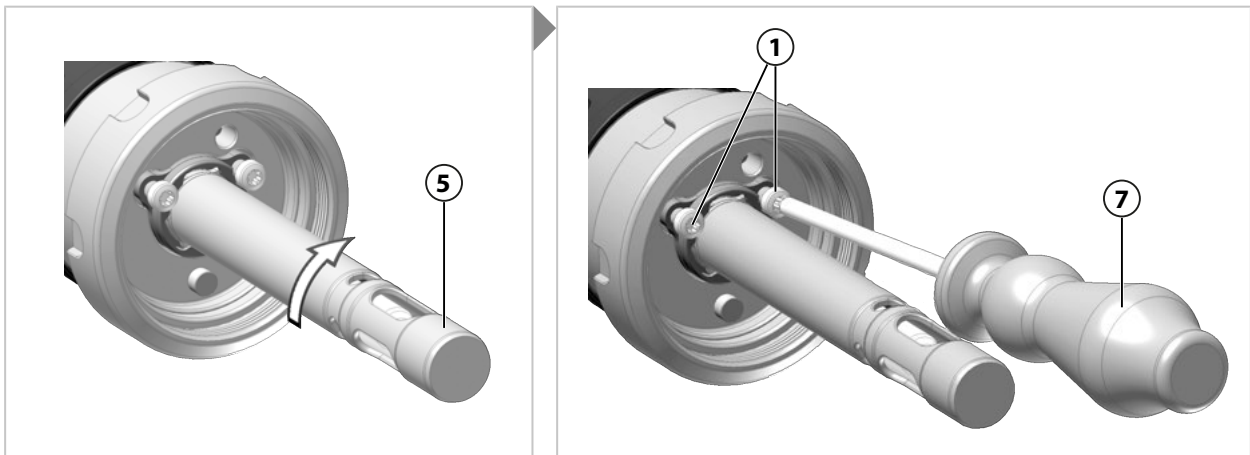

07. Firmly push the immersion tube (5) into the bayonet coupling (6), at the same time rotating around 60° clockwise up to the hard stop.
08. Tighten the screws (1) with a screwdriver of type TX25 (7).
Note: The bayonet coupling is locked by the form-fit screw heads. The immersion tube, however, remains movable to compensate for tolerances.

✓ The immersion tube is installed.

6.3.6 Calibration Chamber: Removal

Note: Service sets ZU0754 or ZU0740 are required to remove the calibration chamber. → *Tools, p. 53*

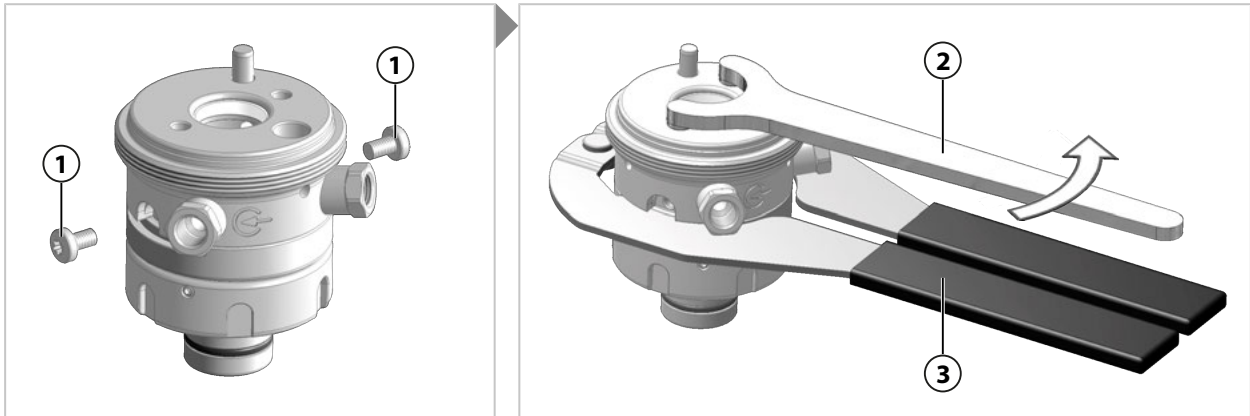

01. Remove the process unit from the drive unit. → *Drive Unit: Removal, p. 38*
02. Remove the screws **(1)** with a screwdriver of type TX25. Keep the screws **(1)** in a safe place for assembly later on.
03. Position the pliers **(3)** and use the face pin spanner wrench **(2)** to loosen the coupling of the split calibration chamber.

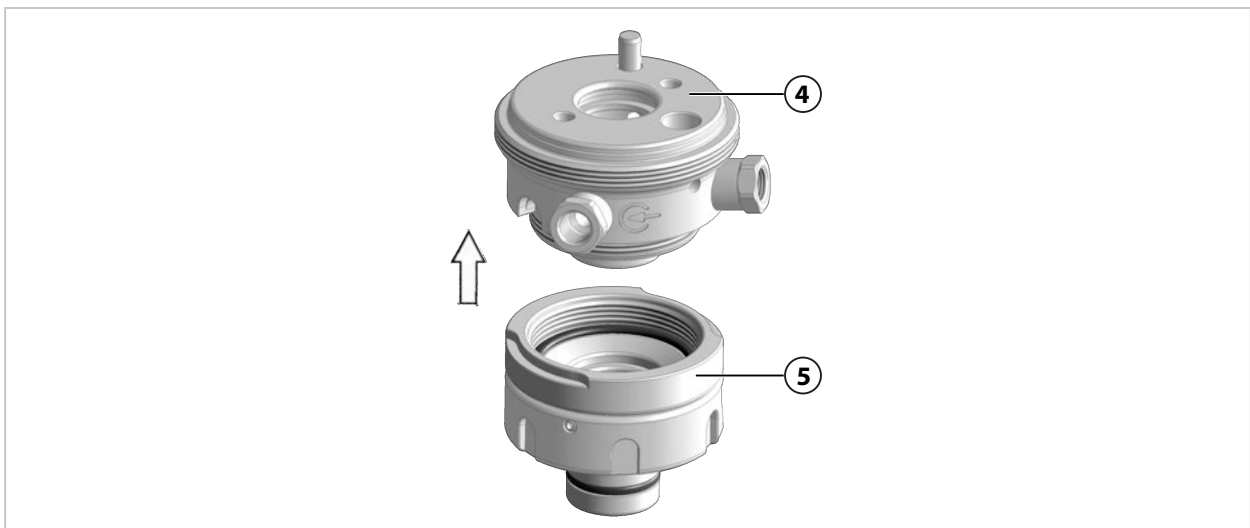

04. Unscrew the top **(4)** from the bottom **(5)** of the calibration chamber and separate the two parts.

✓ The calibration chamber is removed.

6.3.7 Calibration Chamber: Installation

Note: Service sets ZU0754 or ZU0740 are required to install the calibration chamber. → *Tools, p. 53*

Note: To ensure correct assembly of the O-rings and the scraper ring, use the accessory tools ZU0746 and ZU0747. The procedure for handling the accessory tools is described in the relevant documentation. → *Tools, p. 53*

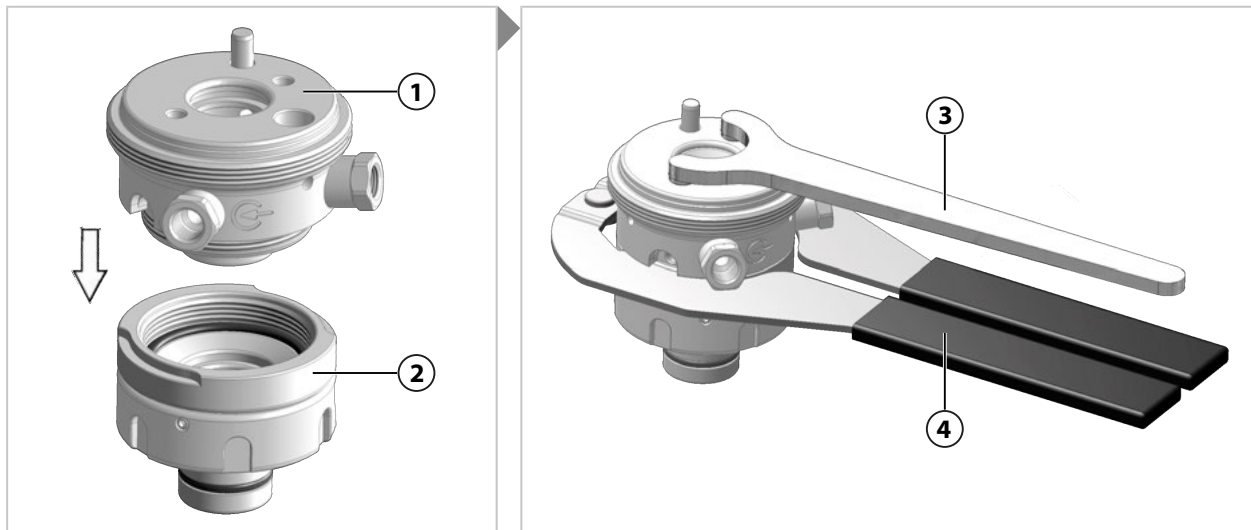

01. Check the O-rings and scraper ring for damage; replace the O-rings and scraper ring if necessary.
→ *Seal Kits, p. 46*
02. Connect the top (1) and the bottom (2) of the calibration chamber and screw together finger tight.
03. Position the pliers (4) and use the face pin spanner wrench (3) to screw the calibration chamber together.

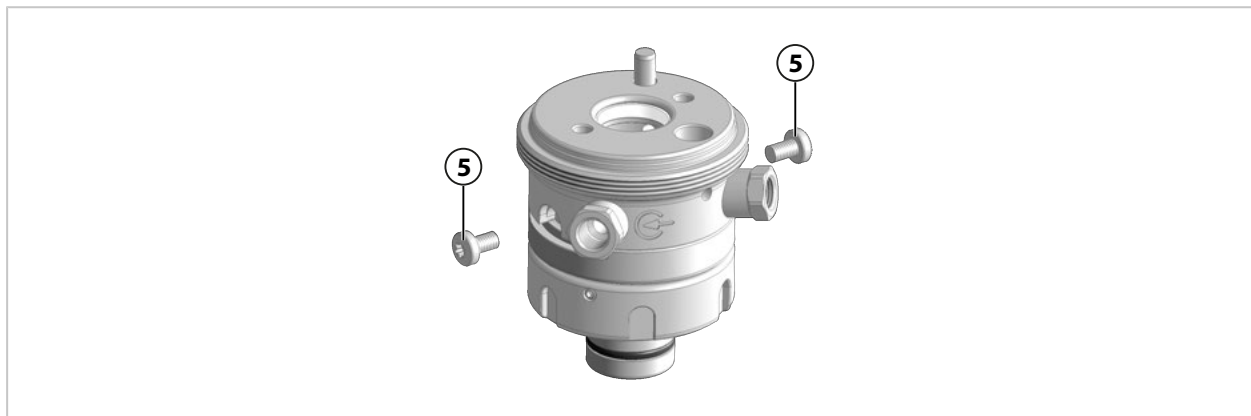

Note: Securing the calibration chamber with the two screws is not possible until the top and bottom parts have been firmly screwed together (to the hard stop).

04. Tighten the screws (5) with a screwdriver of type TX25 .

✓ The calibration chamber is installed.

6.3.8 Knick Repair Service

The Knick Repair Service offers professional corrective maintenance for the product to the original quality. Upon request, a replacement unit can be obtained for the period of the repair.

Further information can be found at www.knick.de.

7 Troubleshooting

Malfunction State	Possible Causes	Remedy
Process medium escapes from the leakage bore.	Leaking due to damaged O-rings.	Replace damaged O- rings. ¹⁾ → <i>Seal Kits, p. 46</i>
Sensor glass shattered.	Mechanical impact on the sensor glass (e.g., by process medium).	Replace faulty sensor. → <i>Installing and Removing Sensors, p. 28</i> Remove any glass splinters from the SensoGate WA131. Check immersion tube seal and replace if necessary. → <i>Seal Kits, p. 46</i>
No or wrong measured value displayed.	Faulty sensor.	Replace the sensor. → <i>Installing and Removing Sensors, p. 28</i>
	Defective plug connection or damaged sensor cable.	Fasten plug connection or replace damaged sensor cable. → <i>Installing and Removing Sensors, p. 28</i>
Safeguard "Immersion Lock Without a Mounted Sensor" not working.	Corrosion or clogging by penetrated process medium. ²⁾	Send the SensoGate WA131 to your local contact for repair. → <i>knick.de</i>

See also

→ *Corrective Maintenance, p. 38*

→ *Knick Repair Service, p. 43*

→ *Return, p. 45*

7.1 Malfunction State: Retractable Fitting Does Not Fully Move to the SERVICE or PROCESS Limit Position

01. Increase the drive control pressure up to the maximum permissible value to move fully to the service position (SERVICE limit position) or the process position (PROCESS limit position).
→ *Specifications, p. 60*
✓ Sensor head or service cap is visible in service position (SERVICE limit position). In process position (PROCESS limit position), the sensor head or service cap is not visible.
02. Troubleshooting successful: Check the cause of the malfunction. If required, remove the drive unit. Perform maintenance on the drive unit or check the functionality of the process unit using a replacement drive.
03. Troubleshooting unsuccessful: Stop the process; depressurize or drain off the process medium if necessary. Remove the SensoGate WA131 and send it to your local contact for repair. → *knick.de*

See also

→ *Drive Unit: Removal, p. 38*

→ *Retractable Fitting: Removal, p. 45*

¹⁾ After replacing the damaged O-rings, clean the leakage bores so that any further escape of process medium can be detected.

²⁾ To protect against the penetration of media from outside into the sensor holder, we recommend using the protective cap ZU0759. We recommend rinsing the sensor before removing it in order to prevent entrainment of the process medium in the area of the sensor holders.

8 Decommissioning

8.1 Retractable Fitting: Removal

⚠ WARNING! Risk of explosion from mechanically generated sparks when used in explosive atmospheres. Take appropriate action to prevent mechanically generated sparks. Follow the safety instructions. → *Operation in Hazardous Locations, p. 9*

⚠ WARNING! Process or rinse medium, potentially containing hazardous substances, may escape from the SensoGate WA131 or the process port. Follow the safety instructions. → *Safety, p. 5*

01. Stop the process; depressurize or drain off the process medium if necessary.
 02. Move the SensoGate WA131 into the service position (SERVICE limit position).
→ *Moving into the Service Position (SERVICE Limit Position), p. 27.*
 03. Optional: Set SensoLock to "lock".
 04. Switch off the compressed air supply and vent the compressed air system.
 05. Remove the compressed air for the process and service positions.
 06. Optional: Remove the compressed air for the process and service limit positions.¹⁾
 07. Remove the sensor. → *Installing and Removing Sensors, p. 28*
 08. Remove the outlet hose.
 09. Optional: Remove installed safety accessories (e.g., ZU0818 retainer clamp).
 10. Loosen the process connection.
 11. Remove the SensoGate WA131 from the customer's process port.
 12. Seal off the process port appropriately.
- ✓ The retractable fitting is removed.

8.2 Return

If required, send the product in a clean condition and securely packed to your local contact.
→ *knick.de*

If there has been contact with hazardous substances, the product must be decontaminated or disinfected prior to shipment. The consignment must always be accompanied by a corresponding return form (declaration of decontamination) to prevent service employees being exposed to potential hazards. → *knick.de*

8.3 Disposal

Local codes and regulations must be observed when disposing of the product.

The SensoGate WA131 can contain various materials, depending on the version concerned.
→ *Product Code, p. 12*

¹⁾ Availability dependent on the ordered version → *Product Code, p. 12*

9 Spare Parts, Accessories, and Tools

9.1 Seal Kits

The seal kits are available in different materials.

The smaller seal kits ("Set X/1") only contain O-rings for direct contact with the process medium.

The extended seal kits ("Set X/2") also include O-rings for contact with the rinse medium.

Each seal kit comes with an accompanying slip that provides information about the package contents, where the O-rings are to be installed, and where the lubrication points are. Replacement O-rings must be greased with the lubricant that is supplied.

To ensure correct installation of the O-rings and the scraper ring, we recommend using the accessory tools ZU0746 and ZU0747. The procedure for handling the accessory tools is described in the relevant product documentation. → *Tools, p. 53*

Seal Kits		Order Code	
Process connection with flange, dairy pipe, thread (male), Tri-Clamp	Set A/1	Process-wetted seal material: FKM	ZU0689/1
	Set A/2	Process-wetted seal material: FKM, wetted by rinse medium: FKM	ZU0829
	Set B/1	Process-wetted seal material: EPDM	ZU0690/1
	Set B/2	Process-wetted seal material: EPDM, wetted by rinse medium: EPDM	ZU0830
	Set E/1	Process-wetted seal material: EPDM FDA	ZU0692/1
	Set E/2	Process-wetted seal material: EPDM FDA, wetted by rinse medium: EPDM FDA	ZU0831
	Set K/1	Process-wetted seal material: FFKM	ZU0691/1
	Set K/2	Process-wetted seal material: FFKM, wetted by rinse medium: FFKM	ZU0832
	Set H/1	Process-wetted seal material: FFKM-FDA	ZU0871
	Set H/1	Process-wetted seal material: FFKM-FDA, wetted by rinse medium: FFKM-FDA	ZU0872
Ingold-socket process connection	Set A/1	Process-wetted gasket material: FKM	ZU0693/1
	Set A/2	Process-wetted seal material: FKM, wetted by rinse medium: FKM	ZU0833
	Set B/1	Process-wetted seal material: EPDM	ZU0694/1
	Set B/2	Process-wetted seal material: EPDM, wetted by rinse medium: EPDM	ZU0834
	Set E/1	Process-wetted seal material: EPDM FDA	ZU0696/1
	Set E/2	Process-wetted seal material: EPDM FDA, wetted by rinse medium: EPDM FDA	ZU0835
	Set K/1	Process-wetted seal material: FFKM	ZU0695/1
	Set K/2	Process-wetted seal material: FFKM, wetted by rinse medium: FFKM	ZU0836
	Set H/1	Process-wetted seal material: FFKM-FDA	ZU0873
	Set H/1	Process-wetted seal material: FFKM-FDA, wetted by rinse medium: FFKM-FDA	ZU0874

Note: Further seal kits are available on request.

Seal Kits for Flange or Dairy-Pipe Process Connection

Note: All dimensions are given in millimeters.

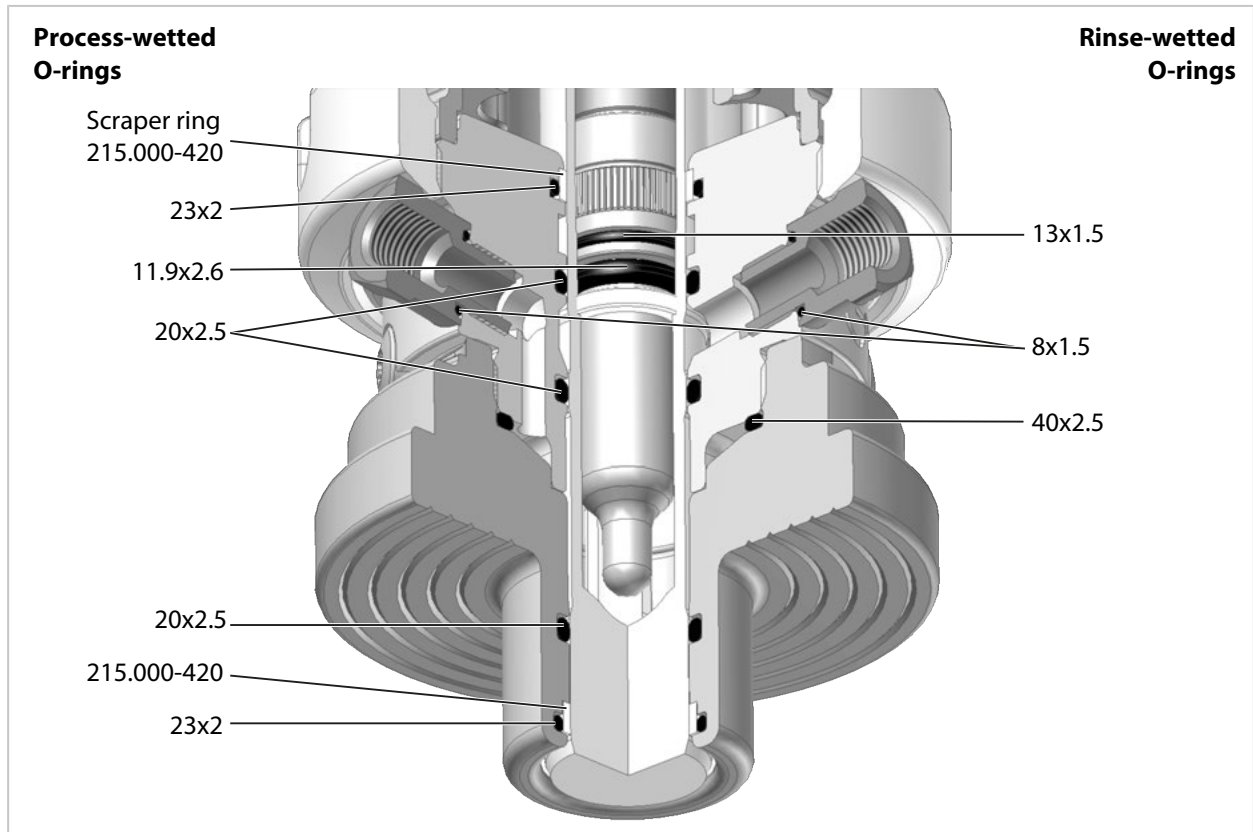



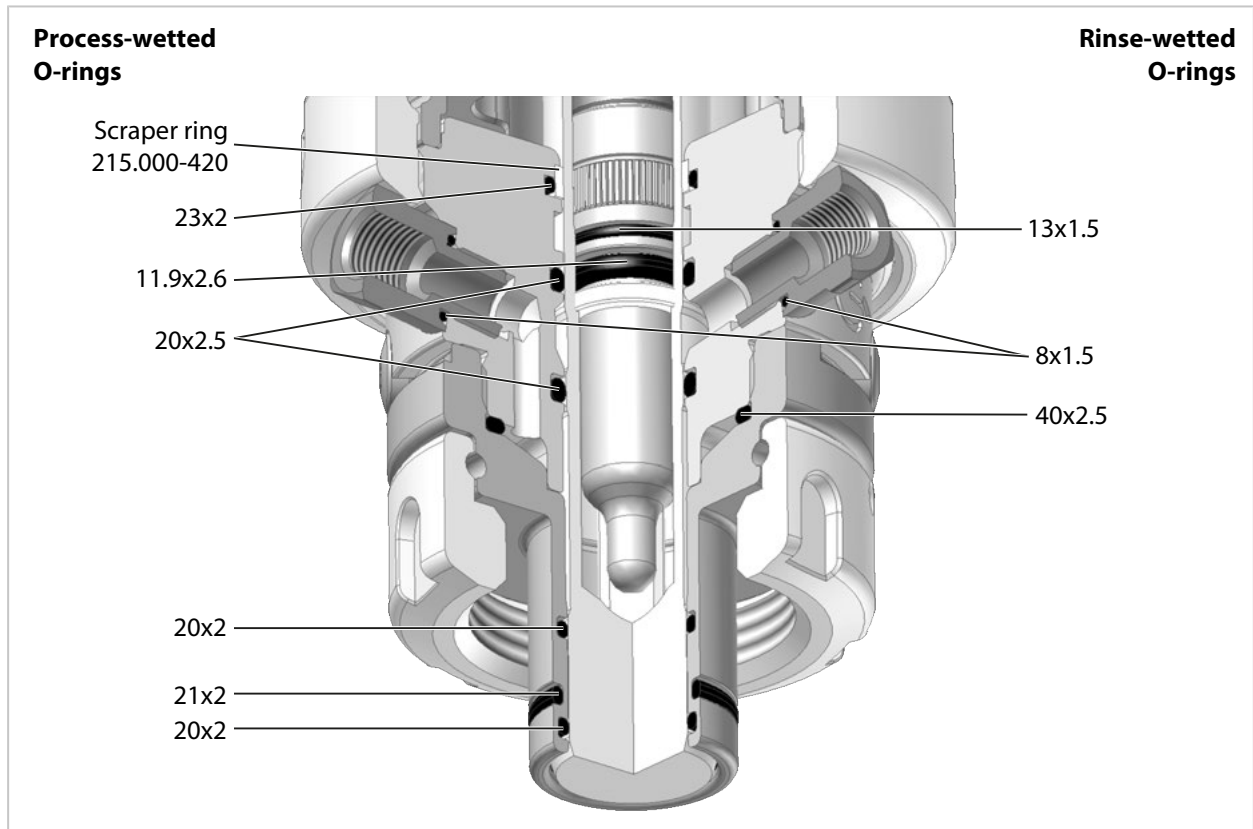

Seal Kits for Ingold-Socket Process Connection

Note: All dimensions are given in millimeters.

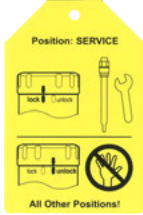
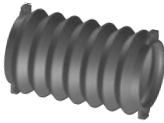

9.2 Spare Parts

	<p>Metal Immersion Tube, Short (149 mm)</p> <p>Materials:</p> <p>ZU0722, 1.4571 stainless steel¹⁾ ZU0853, Hastelloy ZU0893, titanium</p>
	<p>Metal Immersion Tube, Long (204 mm)</p> <p>Materials:</p> <p>ZU0723, 1.4571 stainless steel¹⁾ ZU0854, Hastelloy ZU0894, titanium</p>
	<p>Plastic Immersion Tube, Short (149 mm)</p> <p>Materials:</p> <p>ZU0825, PP ZU0724, PEEK (HD) ZU0726, PVDF (HD)</p>
	<p>Plastic Immersion Tube, Long (204 mm)</p> <p>Materials:</p> <p>ZU0826, PP ZU0725, PEEK (HD) ZU0727, PVDF (HD)</p>
	<p>Safety Label</p> <p>The safety label provides information on the safeguard "Immersion Lock Without a Mounted Solid-Electrolyte Sensor". → <i>Safeguards, p. 6</i></p> <p>Damaged or lost safety labels will be replaced on request.</p>
	<p>ZU0739 Bellows</p> <p>The bellows (only used on versions with liquid-electrolyte sensors) protect the fitting beneath the pressure chamber against external contamination and wear.</p>
	<p>ZU0889 Outlet Hose</p> <p>The outlet hose is used to discharge calibration, cleaning, or rinse media from the calibration chamber. → <i>Outlet Hose: Installation, p. 23</i></p>
	<p>ZU0760 Scraper Ring, Reinforced, PTFE/PEEK</p> <p>A reinforced scraper ring (with PEEK edge) for applications with adhering, sticky media. Use the ZU0746 accessory tool to mount the scraper ring properly.</p>

¹⁾ Material 1.4571: alternatively 1.4404 at discretion of manufacturer

9.3 Accessories



ZU0759 and ZU0759/1 Protective Cap

The protective cap protects against the effects of weather exposure and prevents the ingress of external liquids or particles into the area of the sensor connections.

ZU0759: suitable for versions with solid-electrolyte sensors

ZU0759/1: suitable for versions with liquid-electrolyte sensors

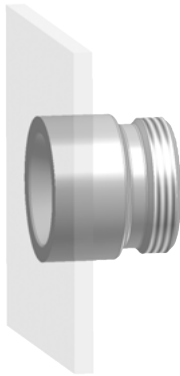

ZU0717 (Straight) Weld-In Socket for Boiler Walls

Process connection: Ingold socket (Ø 25 mm, G1¼)

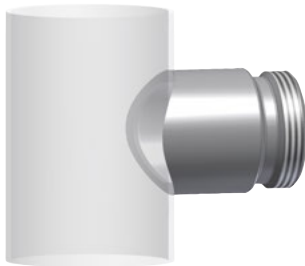

ZU0717/DN (Straight) Weld-In Socket for Pipelines

Process connection: Ingold socket (Ø 25 mm, G1¼)

adapted to DN50 ZU0717/DN50

adapted to DN65 ZU0717/DN65

adapted to DN80 ZU0717/DN80

adapted to DN100 ZU0717/DN100

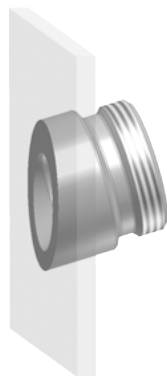

ZU0718 (15° Incline) Weld-In Socket for Boiler Walls

Process connection: Ingold socket (Ø 25 mm, G1¼)



ZU0718/DN (15° Incline) Weld-In Socket for Pipelines

for connecting with Ingold socket (Ø 25 mm, G1¼)

adapted to DN50 ZU0718/DN50

adapted to DN65 ZU0718/DN65

adapted to DN80 ZU0718/DN80

adapted to DN100 ZU0718/DN100

Weld-in sockets with an HSD (Handling Safety Design) safety function feature special grooves on the sealing surface for the process connection O-ring. These grooves prevent the O-ring from sealing if the Ingold coupling nut loosens inadvertently when process pressure is present. A minor leak means the loosening can be detected quickly and remedied before the Ingold coupling nut comes loose from the thread completely. This increases safety for personnel.



ZU0922 (Straight) Safety Weld-In Socket HSD for Boiler Walls

Process connection: Ingold socket (Ø 25 mm, G1¼)



ZU0922/DN (Straight) Safety Weld-In Socket HSD for Piping

Process connection: Ingold socket (Ø 25 mm, G1¼)

- adapted to DN50 ZU0922/DN50
- adapted to DN65 ZU0922/DN65
- adapted to DN80 ZU0922/DN80
- adapted to DN100 ZU0922/DN100



ZU0923 (15° Incline) Safety Weld-In Socket HSD for Boiler Walls

Process connection: Ingold socket (Ø 25 mm, G1¼)



ZU0923/DN (15° Incline) Safety Weld-In Socket HSD for Piping

Process connection: Ingold socket (Ø 25 mm, G1¼)

- adapted to DN50 ZU0923/DN50
- adapted to DN65 ZU0923/DN65
- adapted to DN80 ZU0923/DN80
- adapted to DN100 ZU0923/DN100



RV01 Check Valve

The RV01 check valve prevents process medium or calibration, cleaning, or rinse media from flowing back into the inlet. The check valve is selected using a product code.

Check Valve		RV01	-	-	-	-	-
Housing material, valve body	Stainless steel 1.4404			H			
	PEEK			E			
Seal material	FKM				A		
	EPDM				B		
	FFKM				C		
	FKM-FDA				F		
	EPDM-FDA				E		
	FFKM-FDA				H		
Inlet connection, female thread	G $\frac{1}{4}$ "					4	
	G $\frac{1}{8}$ "					8	
Outlet connection, male thread	G $\frac{1}{4}$ "						4
	G $\frac{1}{8}$ "						8

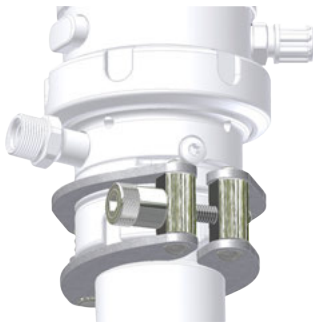

ZU0818 Retainer Clamp for Ingold Socket, 25 mm

The retainer clamp prevents the coupling nut of the Ingold socket (25 mm) screw joint from accidentally coming loose.

The wires of the retainer clamp connect the SensoGate WA131 to the customer's process port. A locking lug on the retainer clamp engages in the groove of the coupling nut (form-fit).

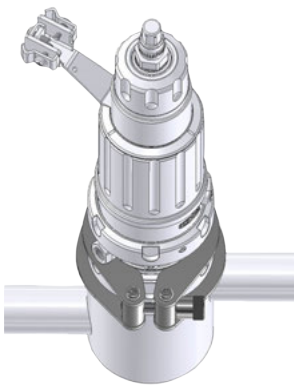

ZU1055 Retainer Clamp for Process Connection K8

The retainer clamp prevents the coupling nut of the screw joint for a K8 process connection from accidentally coming loose.

The wires of the retainer clamp connect the SensoGate WA131 to the customer's process port. A locking lug on the retainer clamp engages in the groove of the coupling nut (form-fit).

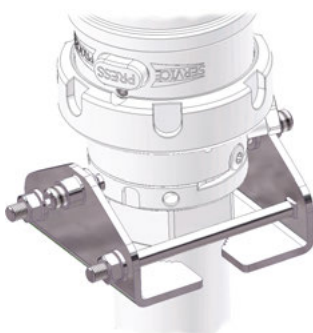

ZU0877 Locking Clamp for Process Connection G1", G1 1/4", R1", R1 1/4", 1" NPT

The locking clamp prevents the process screw joint of a SensoGate WA131 with threaded connection from accidentally coming loose. The locking clamp is available for process connections with the following threads: G1", G1 1/4", R1", R1 1/4", 1" NPT.

The locking clamp can be used with threaded couplings with a minimum length of 10 mm and an outer diameter of 39 mm to 57 mm.

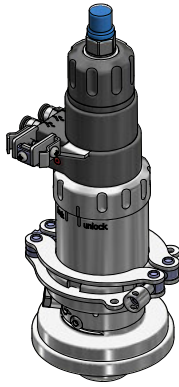

ZU1138 Retainer Clamp for SensoGate Retractable Fitting

The accessory prevents the screw joint between the retractable fitting's drive unit and the process connection from accidentally coming loose. This serves to increase safety during operation of the retractable fitting.

The retainer clamp wires connect the drive unit of the SensoGate WA131 to the coupling nut. The locking lugs on the retainer clamp engage in the grooves of the coupling nut (form-fit) and secure the screw joint.



Flange Protector

The flange protectors protect plastic process connections with DIN flanges and nominal sizes of DN 80 or DN 100 from contact with the process medium.

Materials:

- ZU0755, PEEK/FFKM DN 80
- ZU0756, PEEK/FFKM DN 100
- ZU0757, PVDF/FFKM DN 80
- ZU0758, PVDF/FFKM DN 100

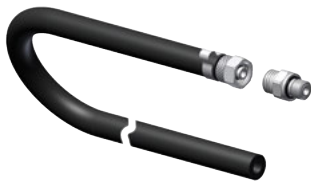

ZU0887 Inlet Hose

The inlet hose is used to supply calibration, cleaning, or rinse media to the retractable fitting calibration chamber. → *Inlet Hose (Option): Installation, p. 24*

- Thread: G 1/8"
- Length: 3 m
- Nominal size: DN 8
- Hose material: EPDM
- Connection nozzle material: Stainless steel
- O-ring material 8x1.5: EPDM
- O-ring material 4.5x1.5: EPDM



- ZU0670/1 Air Supply for Pressurized Sensors 0.5-4 bar**
- ZU0670/2 Air Supply for Pressurized Sensors 1-7 bar**
- ZU0713 Hose, 20 m (Extension for ZU0670)**

This assembly group maintains the defined gauge pressure in the sensor pressure chamber in versions of the SensoGate WA131 for liquid-electrolyte sensors.



ZU0859 Limit Switch, Electrical

The ZU0859 limit switch converts the pneumatic limit signals from the SensoGate WA131 into electrical output signals. The electrical connections are routed through a cable.

9.4 Tools

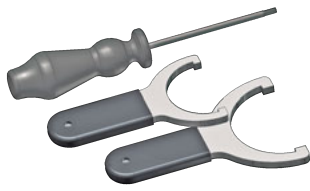

ZU0680 SensoGate Service Set, Basic Equipment

This tool set is suitable for minor maintenance work. It allows easy separation of the drive unit from the process unit, mounting of an Ingold socket, and replacement of the immersion tube, including O-ring maintenance.



ZU0740 SensoGate Service Set, Maintenance, Repair, Modification

This tool set contains all the tools required to carry out extensive maintenance and corrective maintenance, as well as to modify the product. SensoGate WA131 can be fully dismantled using this tool set.



ZU0754 SensoGate Service Set, Calibration Chamber

This tool set is suitable for maintenance work on the calibration chamber and its seals. It allows easy separation of the split calibration chamber.



ZU0746 Accessory Tool for Scraper Ring

The ZU0746 accessory tool allows easy and correct fitting of the scraper rings in the calibration chamber of the SensoGate WA131.

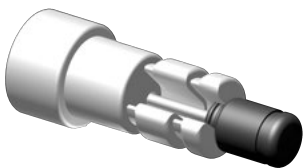

ZU0747 Accessory Tool for O-Rings 20 x 2.5

The ZU0747 accessory tool allows easy and correct fitting of the O-rings 20 x 2.5 in the calibration chamber of the SensoGate WA131.



ZU0647 Sensor Spanning Wrench

The ZU0647 sensor spanning wrench is used to properly tighten sensors. It prevents damage to the plastic thread of the sensor head PG 13.5 caused by applying an excessive tightening torque (e.g., when using an open-end wrench).

10 Dimension Drawings

Retractable Fitting for Solid-Electrolyte Sensor, Short Immersion Depth

Note: All dimensions are given in millimeters [inches].

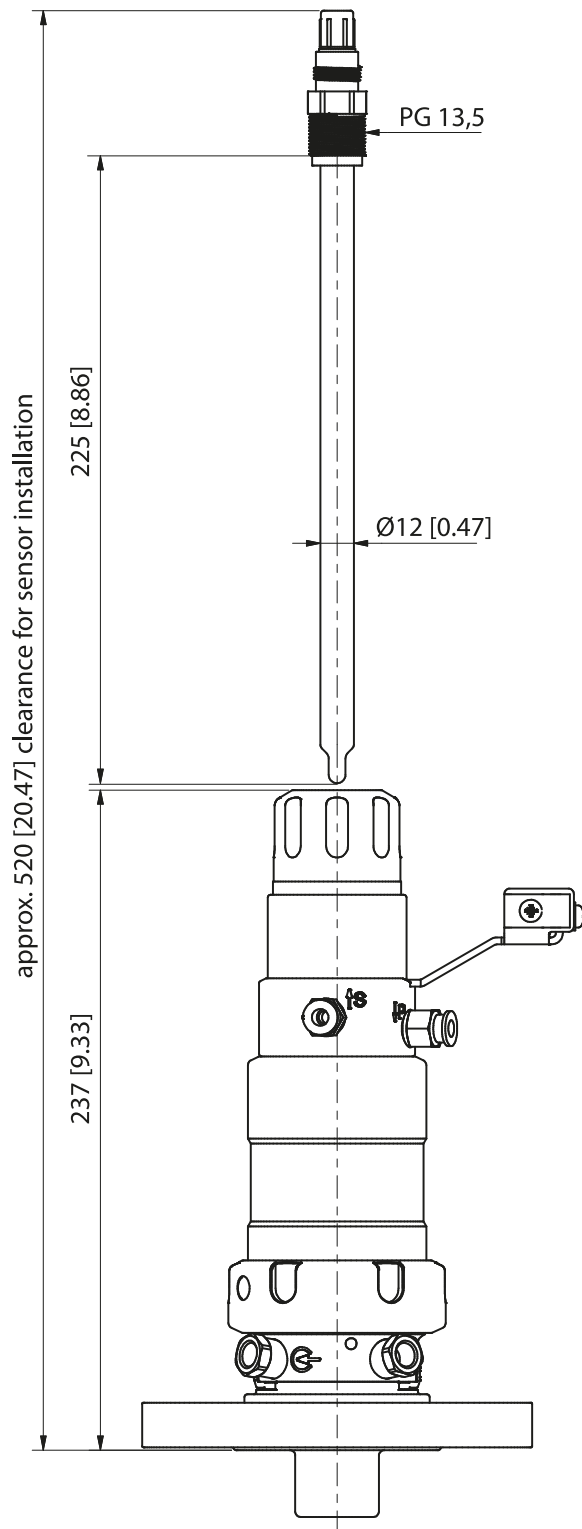

Retractable Fitting for Solid-Electrolyte Sensor, Long Immersion Depth

Note: All dimensions are given in millimeters [inches].

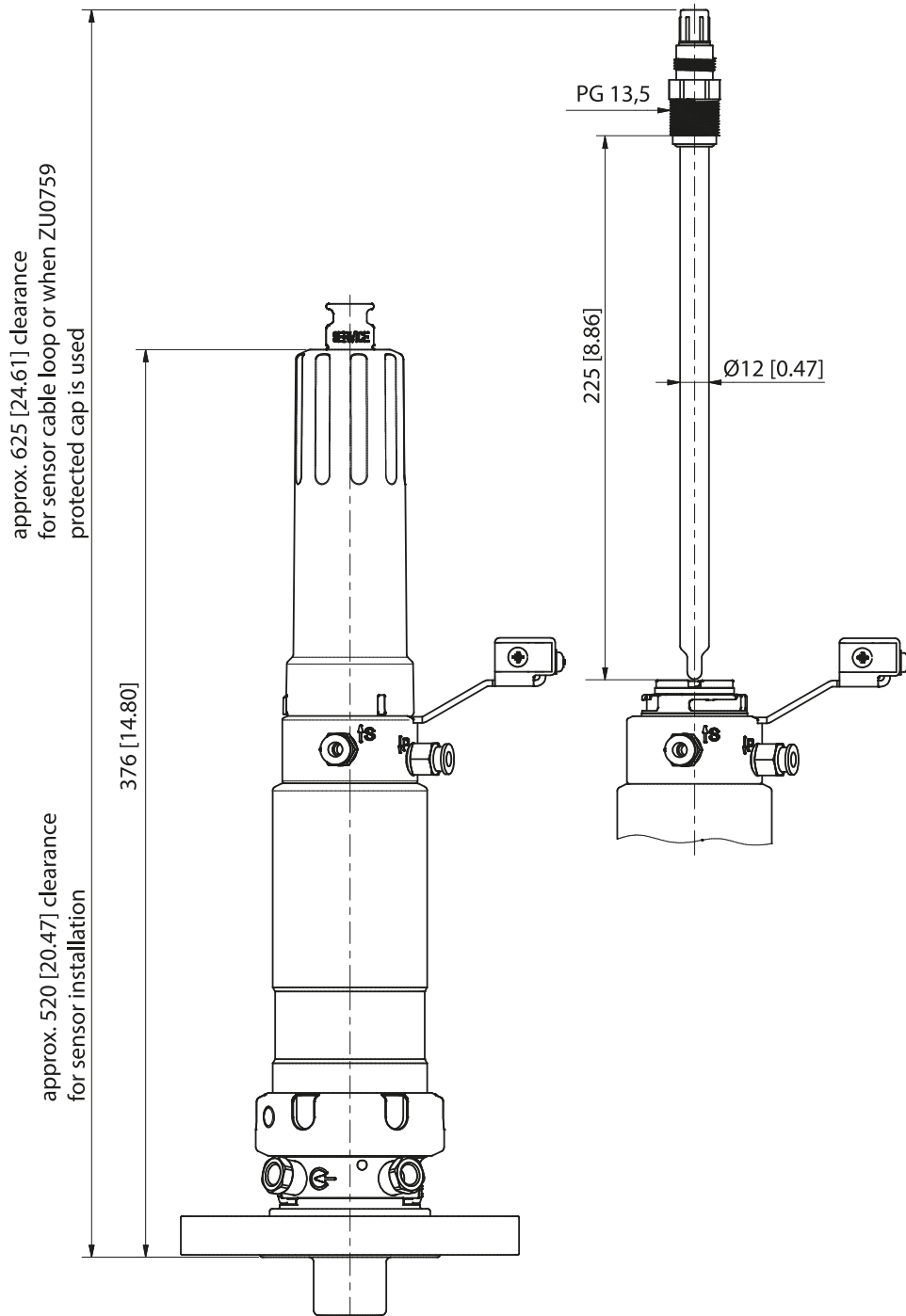

Retractable Fitting for Liquid-Electrolyte Sensor, Short and Long Immersion Depth

Note: All dimensions are given in millimeters [inches].

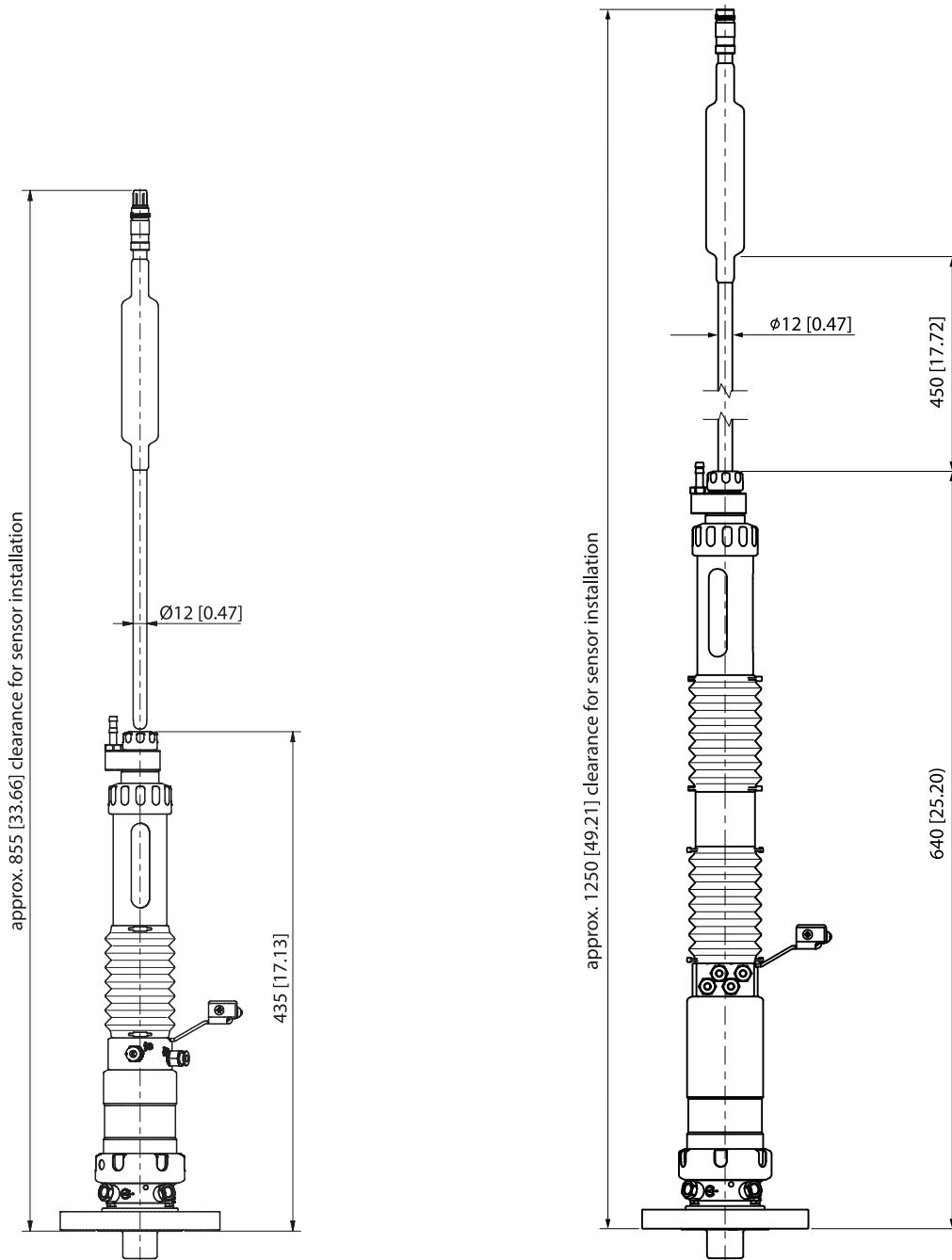

Short immersion depth

Long immersion depth

Process Connection

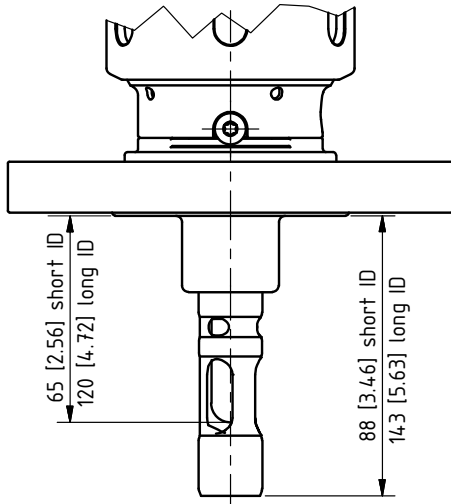

Flange, loose, 1.4571, PN10/16, DN 32 ... DN 100
 Flange, loose, 1.4571, PN40, DN 32 ... DN 100

Flange, loose, ANSI 316, 150 lbs, 1½" ... 4"
 Flange, loose, ANSI 316, 300 lbs, 1½" ... 3"

Short and long immersion depth (ID)

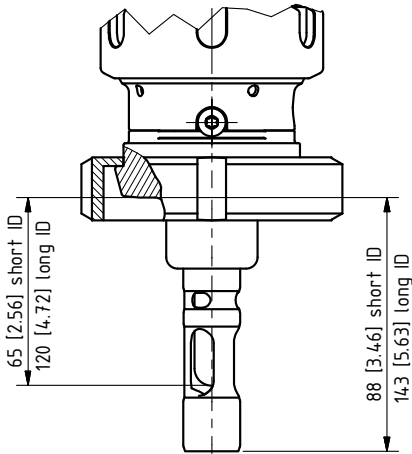

Dairy pipe DN 50 ... DN 100
 Short and long immersion depth (ID)

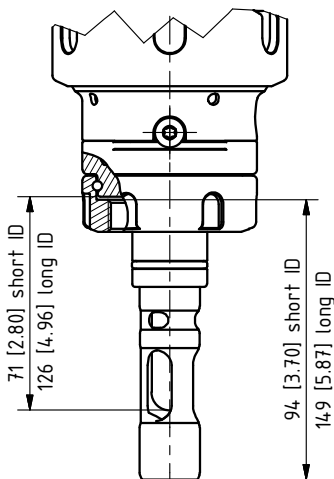

25 mm Ingold socket
 Short and long immersion depth (ID)

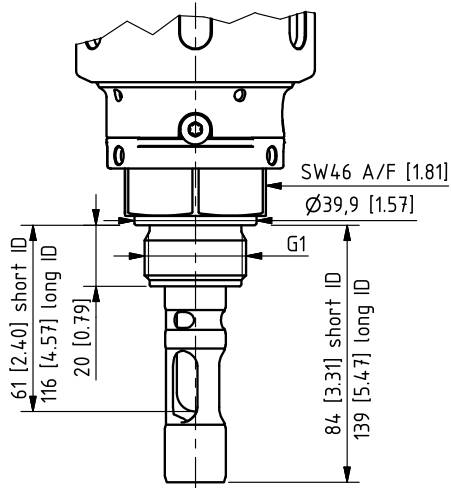

G1" male
Short and long immersion depth (ID)

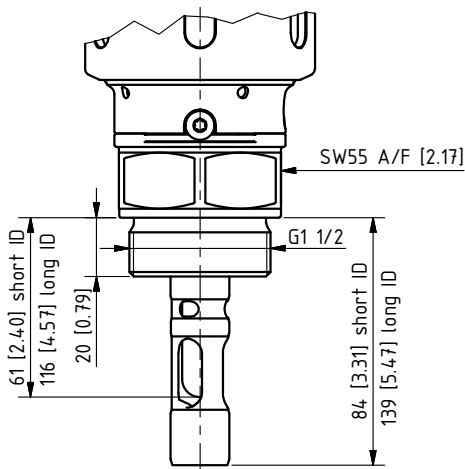

G1 1/2" male
Short and long immersion depth (ID)

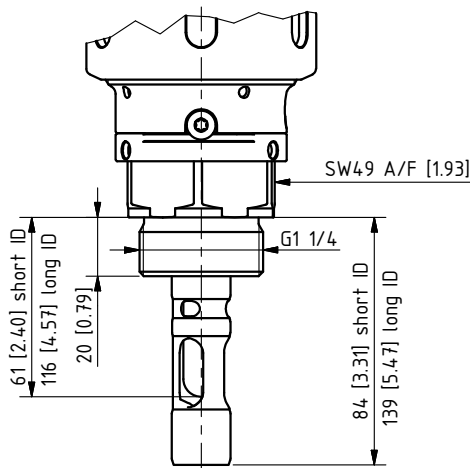

G1 1/4" male
Short and long immersion depth (ID)

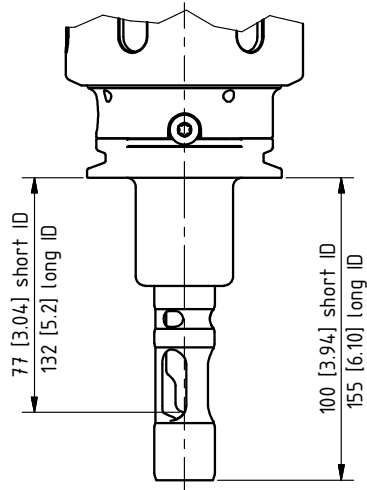

Clamp 1.5" and clamp 2"
Short and long immersion depth (ID)

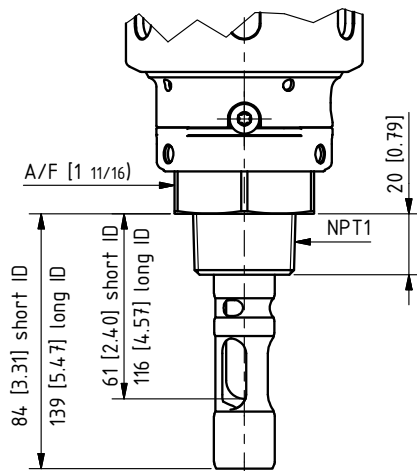

1" NPT male
Short and long immersion depth (ID)

11 Specifications

Permissible process pressure and temperature, general	
1.4571/Hastelloy/titanium process connection	
0 ... 140 °C (32 ... 284 °F)	10 bar (150 psi)
PEEK HD process connection	
0 ... 140 °C (32 ... 284 °F)	10 bar (150 psi)
PVDF HD process connection	
0 ... 120 °C (32 ... 248 °F)	10 bar (150 psi)
120 °C ... 140 °C (248 ... 284 °F) 30 min	6 bar (90 psi)
PEEK/PVDF process connection	
0 ... 40 °C (32 ... 104 °F)	6 bar (90 psi)
40 ... 120 °C (104 ... 248 °F)	Falling linearly to 2 bar (29 psi)
Process connection PP	
5 ... 30 °C (41 ... 86 °F)	6 bar (90 psi)
30 ... 80 °C (86 ... 176 °F)	Falling linearly to 1 bar (14.5 psi)
Only when static in service position (SERVICE limit position)	
0 ... 40 °C (32 ... 104 °F)	16 bar (230 psi)
5 ... 20 °C (41 ... 68 °F): PP	10 bar (150 psi)
Permissible rinsing pressure and temperature	
5 ... 90 °C (41 ... 194 °F)	6 bar (90 psi)
Permissible pressure for SERVICE/PROCESS control	4 ... 7 bar (58 ... 101 psi)
Ambient temperature	-10 ... 70 °C / (14 ... 158 °F)
Degree of protection	IP66
Housing material	Stainless steel, PEEK, PP, EPDM, Duran
Sensors	→ <i>Product Code, p. 12</i>
Process connections	→ <i>Product Code, p. 12</i>
Quality of compressed air	
Standard	according to ISO 8573-1:2001
Quality class	3.3.3 or 3.4.3
Solid contaminants	3 (max. 5 µm, max. 5 mg/m ³)
Water content for temperatures > 15 °C (59 °F)	Class 4, pressure dew point 3 °C (37.4 °F) or lower
Water content for temperatures 5 ... 15 °C (41 ... 59 °F)	Class 3, pressure dew point -20 °C (-4 °F) or lower
Oil content	Class 3 (max. 1 mg/m ³)
Connections	
Compressed air	Push-in fitting DN 4/6
Inlet	Female thread G 1/8"
Outlet	Female thread G 1/8" with connection nozzle for hose DN 8 EPDM 3 m
For pressurized sensors	Hose connection DN 6, pressure in calibration chamber 0.5 ... 1 bar (7.25 ... 14.5 psi) above process pressure (max. 7 bar / 101.5 psi)
Immersion depths/Installation dimensions	→ <i>Dimension Drawings, p. 54</i>
Wetted materials	→ <i>Product Code, p. 12</i>
Weight	Depending on material and version

Abbreviations

A/F	Width across flats
ATEX	Atmosphères Explosibles (explosive atmospheres)
CE	Conformité Européenne (European conformity)
CLP	Classification, labeling, and packaging
DIN	Deutsches Institut für Normung (German Institute for Standardization)
DN	Diamètre nominal (nominal size)
EPDM	Ethylene propylene diene monomer rubber
EU	European Union
FDA	U.S. Food and Drug Administration
FFKM	Perfluoro rubber
FKM	Fluoro rubber
ID	Immersion depth
IEC	International Electrotechnical Commission
IP	International Protection / Ingress Protection
ISO	International Organization for Standardization
KEMA	Keuring van Elektrotechnische Materialen te Arnhem (inspection of electrical equipment in Arnhem)
LED	Light-emitting diode
NSF-H1	Lubricants approved by the US organization NSF (National Sanitation Foundation) for the food and feed industry.
PCS	Process control system
PEEK	Polyether ether ketone
PP	Polypropylene
PVDF	Polyvinylidene fluoride
USDA-H1	Lubricants approved by the U.S. Department of Agriculture (USDA).

Technical Terms

CE Marking

Manufacturer's declaration, in accordance with EU Regulation 765/2008, that the product is in conformity with the applicable requirements set out in the European Union harmonization legislation providing for its affixing.

Corrective Maintenance

Measures taken to return an item under review to an operational condition, with the exception of improvements.

Hazard

A hazard is defined as a potential source of damage. The term "hazard" can be specified to further describe the origin or nature of the expected damage. (Source: EN ISO 12100)

Highly Efficient Charge Generating Mechanism

A highly efficient charge generating mechanism is [...] any charging mechanism stronger than manual rubbing of surfaces. (Source: EN ISO 80079-36)

Inspection

Measures for determining and assessing the actual condition of an item under review, including determining the causes of wear and deriving the necessary steps for future use.

Maintenance

Combination of all technical, administrative and managerial actions during the life cycle of an item intended to retain it in, or restore it to, a state in which it can perform the required function. (Source: EN 13306 Maintenance – Maintenance terminology)

Preventive Maintenance

Measures for maintaining the target condition [...] and delaying the reduction of the available wear margin of an item under review.

Risk

Combination of the probability of occurrence of harm and the severity of that harm (source: EN ISO 12100)

Risk Assessment

Overall process of risk analysis and risk evaluation (source: EN ISO 12100)

Zone 0

Area in which an explosive gas atmosphere is present continuously or for long periods or frequently. (Source: IEC 60079-10-1)

Index

A

Accessories	49
Accessory tool	53
Accompanying slip, seal kit	46
Ambient temperature	60
ATEX certificate	9

B

Bellows	48
---------	----

C

Calibration chamber	
Accessory tool, O-rings	53
Accessory tool, scraper ring	53
Installation	43
Removal	42
Certificates	9
Changes, retractable fitting	19
Charging, electrostatic	9
Coding, product code	12
Commissioning	26
Connection point	22
Connections	60
Corrective maintenance	38
Corrosion	44

D

Declaration of decontamination	45
Declaration of no objection	45
Decommissioning	45
Degree of protection against dust and humidity	60
Design, retractable fitting	16
Dimension Drawings	54
Dimensions	54
Disposal	45
Drinking water connection	
Check valve	24
Contamination	24
EN 1717	24
Drive unit	
Design	16
Installation	39
Nameplate	14
Removal	38

E

Electrostatic charging	9
Environmental damage	5
Environmental factors	7
Equipotential bonding	
Avoidance of possible ignition hazards	9
Connection	29
Equipotential bonding cable	31

F

First inspection	35
Flange protector	25
Functional description, retractable fitting	16
Functional test	
Immersion lock without a liquid-electrolyte sensor	36
Immersion lock without a solid-electrolyte sensor	35

G

Genuine spare parts	10
---------------------	----

H

Hazardous locations	9
Hazardous substances	9
Highly efficient charge-generating mechanisms	9

I

Ignition sources	9
Immersion Lock Without a Mounted Liquid-Electrolyte	
Sensor	
Function	6
Immersion Lock Without a Mounted Solid-Electrolyte	
Sensor	
Function	6
Inlet	60
Inlet hose	24
Inspection	35
Functional tests	35
Inspection intervals	35
Installation	22
Inlet hose	24
Outlet hose	23
Retractable fitting	22
Safety accessories	22
Installation location	9
Installation, retractable fitting	22
Intended use	5
Introductory safety chapter	2
IP degree of protection	60

L

Leak	44
Leakage bores	6
Limit positions	20
SensoLock	6
Lubricants, approved	37

M

Maintenance	35
Maintenance intervals	35
Maintenance instructions	19
Markings	16
Material characteristics	37
Calibration chamber	37
Immersion tube	37
Model designation	12
Coding	11
Modifications	19

N

Nameplate	
Drive unit, with Ex approval	14
Drive unit, without Ex approval	15
Process unit, with Ex approval	14
Process unit, without Ex approval	15
Notes on safety information	2

O

Order code	11
O-ring, wear	44
Outlet	60

P

Package contents	11
Permissible modifications	19
Personnel	5
Personnel requirements	5
Pressurized sensors	60
Preventive maintenance	10, 35
Lubricants	37
Process connection	16
Change	19
Function	16
Process position	
Description	20
Moving into the	27
Overview of limit positions	20
Process pressure, permissible	60
Process unit	
Design	16
Nameplate	14
Product code	11
Example	11
Property damage	5

Q

Qualified personnel	5
---------------------	---

R

Removal, retractable fitting	45
Repair Service	43
Residual risks	7
Retractable fitting	
Changes	19
Function	16
Installation angle	22
Leaking	44
Main assemblies	16
Return form	45
Returns	45
Rinsing pressure, permissible	60
Risk assessment	7, 9

S

Safeguards	
Overview	6
Retrofit	19
Safety accessories	
Locking clamp	8
Retainer clamp K8	8
Retainer clamp, Ingold socket, 25 mm	8
Safety chapter	5
Safety datasheets	9
Safety instructions	2
Scraper ring, test	43
Seal kits	46
Sensor	
Glass breakage	44
Modification of the sensor holder	19
Spanning wrench	53
Troubleshooting	44
Sensor types, permissible	5
Serial number	
Retractable fitting, with Ex approval	14
Retractable fitting, without Ex approval	15
Service position	
Description	20
Moving into the	27
Overview of limit positions	20
Service sets	53
Spare parts	48
Specifications	60
Supplemental directives	2
Surface temperature, max. permissible	60
Symbols and markings	16

T

Temperature, permissible	60
Tools	
Accessory tools	53
Safety	10
Sensor spanning wrench	53
Service sets	53
Troubleshooting	44
Type designation	11

V

Versions	11
----------	----

W

Warnings	2
----------	---



Knick
Elektronische Messgeräte
GmbH & Co. KG

Headquarters

Beuckestraße 22 • 14163 Berlin
Germany
Phone: +49 30 80191-0
Fax: +49 30 80191-200
info@knick.de
www.knick.de

Local Contacts

www.knick-international.com

Translation of the original instructions
Copyright 2023 • Subject to change
Version 6 • This document was published on August 18, 2023.
The latest documents are available for download on our
website under the corresponding product description.

TA-215.303-KNEN06



101488