

ARF215

Flow-Through Fitting

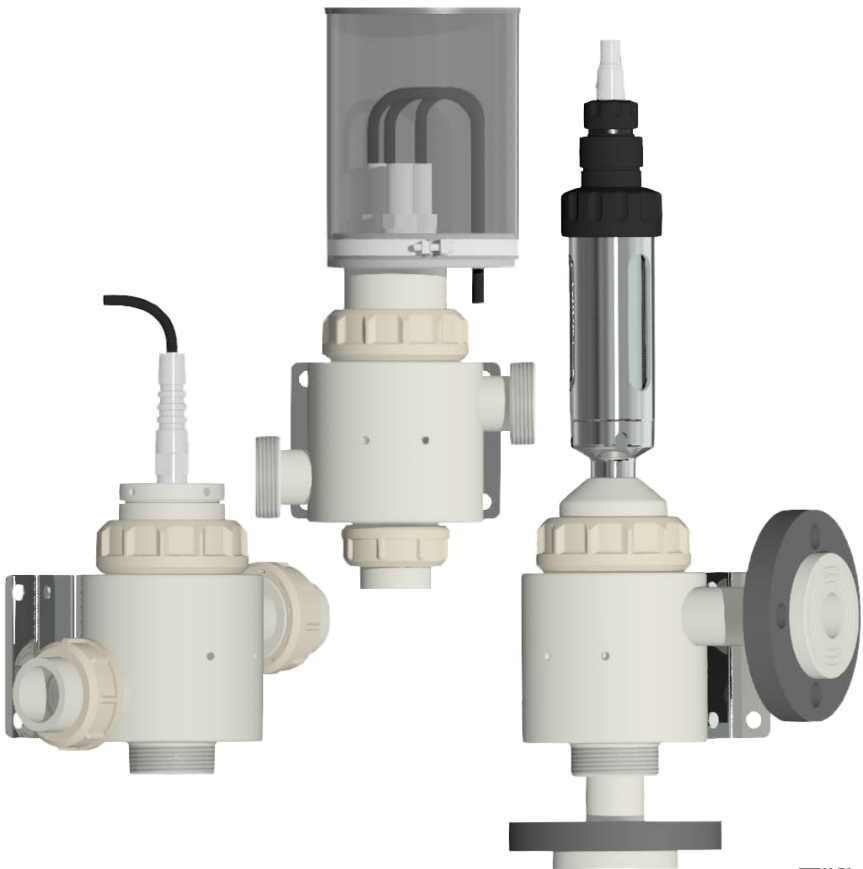

Read before installation.
Keep for future use.



Supplemental Directives

READ AND SAVE THIS DOCUMENT FOR FUTURE REFERENCE. BEFORE ATTEMPTING TO ASSEMBLE, INSTALL, OPERATE OR MAINTAIN THE PRODUCT, PLEASE ENSURE A COMPLETE UNDERSTANDING OF THE INSTRUCTIONS AND RISKS DESCRIBED HEREIN. ALWAYS OBSERVE ALL SAFETY INFORMATION. FAILURE TO COMPLY WITH INSTRUCTIONS IN THIS DOCUMENT COULD RESULT IN SERIOUS INJURY AND/OR PROPERTY DAMAGE. THIS DOCUMENT IS SUBJECT TO CHANGE WITHOUT NOTICE.



These supplemental directives explain how safety information is laid out in this document and what content it covers.

Safety Chapter

This document's safety chapter is designed to give the reader a basic understanding of safety. It illustrates general hazards and gives strategies on how to avoid them.

Warnings

This document uses the following warnings to indicate hazardous situations:

Symbol	Category	Meaning	Remark
	WARNING	Designates a situation that can lead to death or serious (irreversible) injury.	The warnings contain information on how to avoid the hazard.
	CAUTION	Designates a situation that can lead to slight or moderate (reversible) injury.	
<i>None</i>	NOTICE	Designates a situation that can lead to property or environmental damage.	

Symbols Used in this Document





Symbol	Meaning
	Reference to additional information
	Interim or final result in instructions for action
	Sequence of figures attached to an instruction for action
	Item number in a figure
(1)	Item number in text

Table of Contents

1 Safety	5
1.1 Intended Use	5
1.2 Personnel Requirements	5
1.3 Residual Risks	6
1.4 Hazardous Substances	6
1.5 Safety Training	6
2 Product	7
2.1 Package Contents	7
2.2 Product Identification	7
2.3 Example of a Version	7
2.4 Product Code	7
2.5 Nameplate	9
2.6 Design and Function	9
2.7 Installation Position	11
3 Installation	12
3.1 General Installation Instructions	12
3.2 Installation with Threaded Coupling Process Connection	12
3.3 Installation with Flange Process Connection	12
3.4 Installation with Female Thread Process Connection	12
3.5 Wall Mounting	13
3.6 Sensor Adapter Installation	14
Sensor Adapter 3 x PG 13.5	14
SE660 Sensor Adapter	15
SE655/SE656 Sensor Adapter	16
SE604/SE605/SE630 Sensor Adapter	17
Liquid-Electrolyte Sensor Adapter	18
SE670/G1 Sensor Adapter	19
SE680 Sensor Adapter	20
3.7 Protective Cap Installation	21

3.8	Pressure and Leak Test	21
4	Commissioning	22
5	Operation	23
5.1	General Notes on Operation	23
5.2	Safety Instructions on Installing and Removing Sensors	23
5.3	Sensor: Installation and Removal	24
	Sensor Diameter 12 mm, Length approx. 120 mm, and PG 13.5	24
	Liquid-Electrolyte Sensor	25
	Conductivity Sensor	27
6	Maintenance	29
6.1	Sensor Inspection and Maintenance	29
6.2	Knick Premium Service	29
7	Troubleshooting	30
8	Decommissioning	31
8.1	Flow-Through Fitting: Removal	31
8.2	Returns	31
8.3	Disposal	31
9	Specifications	32
10	Dimension Drawings	34
	Appendix	42

1 Safety

This document contains important instructions for the use of the product. Always follow all instructions and operate the product with caution. If you have any questions, please contact Knick Elektronische Messgeräte GmbH & Co. KG (sometimes hereafter referred to as "Knick") using the information provided on the back page of this document.

1.1 Intended Use

The ARF215 is a flow-through fitting for installation in pipes or bypass systems. The product is used to mount up to three sensors for the purpose of liquid analysis.

The defined operating conditions must be observed when using this product.

USE CAUTION AT ALL TIMES WHEN INSTALLING, USING, MAINTAINING OR OTHERWISE INTERACTING WITH THE PRODUCT. ANY USE OF THE PRODUCT EXCEPT AS SET FORTH HEREIN IS PROHIBITED, AND MAY RESULT IN SERIOUS INJURY OR DEATH, AS WELL AS DAMAGE TO PROPERTY. CUSTOMER SHALL BE SOLELY RESPONSIBLE FOR ANY DAMAGES RESULTING FROM OR ARISING OUT OF AN UNINTENDED USE OF THE PRODUCT.

1.2 Personnel Requirements

The operating company must ensure that all employees who use or otherwise come into contact with the product have received adequate training and instruction.

The operating company shall comply and cause its personnel to comply with all applicable laws, regulations, codes, ordinances and relevant industry qualification standards related to product. Failure to comply with the foregoing shall constitute a violation of operating company's obligations concerning the product, including but not limited to an unintended use as described in this document.

The following minimum qualifications for personnel are recommended:

Qualified personnel **Minimum qualification**

Operating personnel	Installing and operating machines and industrial plants
	Measuring and controlling processes
	Detecting and eliminating minor malfunction states
	Ensuring the operability of technical systems based on product documentation

Qualified personnel **Minimum qualification**

Installation and maintenance personnel	Installation, removal, servicing, monitoring, and corrective maintenance of complex pipeline systems
	Installation and removal of pipeline connections
	Inspections for leaks and pressure resistance in pipeline systems
	Commissioning and decommissioning of pipeline sections

Qualified personnel **Minimum qualification**

Assessing processes and equipment with respect to the applicable safety and environmental codes and regulations

1.3 Residual Risks

The product has been developed and manufactured in accordance with generally accepted safety rules and regulations, as well as an internal risk assessment. Despite the foregoing, the product may among others bear the following risks:

Environmental Influences

The effects of moisture, ambient temperature, chemicals, and corrosion can negatively impact the safe operation of the product.

Please observe the following instructions:

- Only operate the ARF215 in compliance with the stated operating conditions.
- If using aggressive chemical process media, adjust the inspection and maintenance intervals accordingly.

1.4 Hazardous Substances

In certain situations (e.g., sensor replacement or corrective maintenance), personnel may come into contact with hazardous substances in the process medium.

The operating company is responsible for conducting a hazard assessment.

See the relevant manufacturers' safety data sheets for hazard and safety instructions on handling hazardous substances.

1.5 Safety Training

Upon request, Knick Elektronische Messgeräte GmbH & Co. KG will provide safety instruction and product training during initial commissioning of the product. Further information is available from the relevant Knick representatives.

2 Product

2.1 Package Contents

- ARF215 in the version ordered
- User Manual

2.2 Product Identification

The different versions of the ARF215 are coded in a product code.

The product code is stated on the nameplate, the delivery note, and the product packaging. → *Nameplate, p. 9*

2.3 Example of a Version

ARF 215		ARF215	-	1	1	3	1	1	0	1
Material	PP-H		1							
Sensor adapter	3 x PG 13.5		1							
Process connection and arrangement	Flange DN 25, 90°				3	1				
Protective cap	Normal							1		
Calibration beaker	Without								0	
Gasket material	EPDM									1

2.4 Product Code

ARF 215		ARF215	-	-	-	-	-	-	-	-
Material	PP-H		1							
	PVDF		2							
Sensor adapter	3 x PG 13.5		1							
	SE660		3							
	SE655(X) / SE656(X)		4							
	SE604 / SE605 / SE630 (G1)		7							
	pH sensor, Ø 12 mm, pressurized		8							
	SE670/G1		E							
	SE680		X							
Process connection and arrangement	Threaded coupling DN 25, 90°				1	1				
	Threaded coupling, DN 25, 180° staggered				1	2				
	Threaded coupling, DN 25, 180° with cleaning connection		1	1	3					

ARF 215	ARF215	-	-	-	-	-	-	-
G1/4", 90°						2	1	
G1/4", 180° staggered						2	2	
G1/4", 180° with cleaning connection				1	2	3		
G1/4", 180° top/top						2	8	
Flange DN 25, 90°						3	1	
Flange DN 25, 180° staggered						3	2	
Flange DN 25, 180° with cleaning connection				1	3	3		
Threaded coupling DN 25, incl. joining pieces, 90°						5	1	
Threaded coupling DN 25, incl. joining pieces, 180° staggered						5	2	
Threaded coupling DN 25, incl. joining pieces, 180° with cleaning connection						5	3	
Flange ANSI 1", 150 lbs., 90°						A	1	
Flange ANSI 1", 150 lbs., 180° staggered						A	2	
Flange ANSI 1", 150 lbs., 180° with cleaning connection				1	A	3		
1/2" NPT, 90°						9	1	
1/2" NPT, 180° staggered						9	2	
1/2" NPT, 180° with cleaning connection				1	9	3		
Protective cap	Without							0
	Normal					1/4		1
	With electrolyte reservoir					1		2
Calibration beaker	Without							0
	With							1
Gasket material	EPDM							1
	FKM							2
	FFKM							3

2.5 Nameplate

The ARF215 is identified by a nameplate.

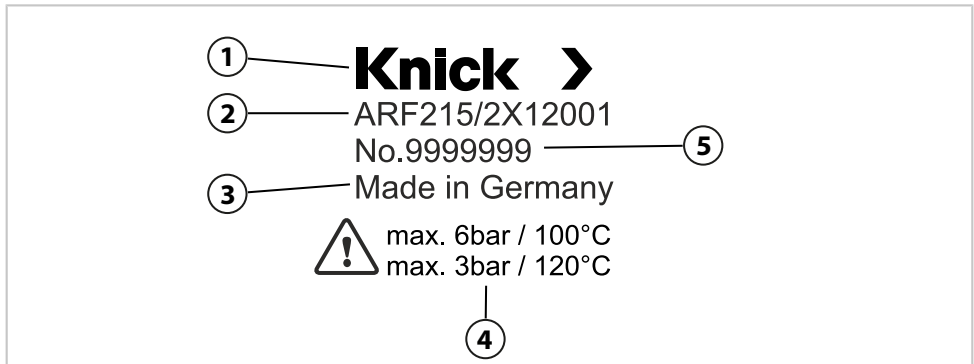

1	Manufacturer	4	Max. operating pressure and temperature range
2	Type (product code)	5	Serial number
3	Origin		

2.6 Design and Function

The ARF215 flow-through fitting is a modular system. Its main components are made of PP-H or PVDF. The product code determines the process connections and their arrangement. Sensor adapters are provided for measuring different process parameters. Depending on the selected sensor adapter, the following process variables are measured:

- pH value
- Conductivity
- Oxygen

DN25 threaded coupling process connection:

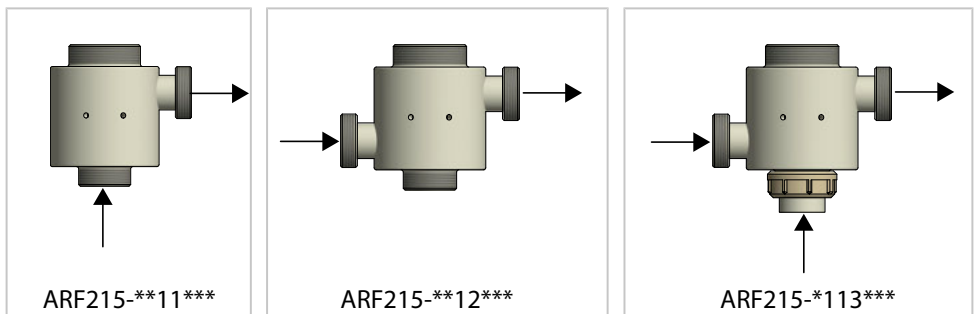

DN25 threaded coupling process connection, incl. joining pieces:

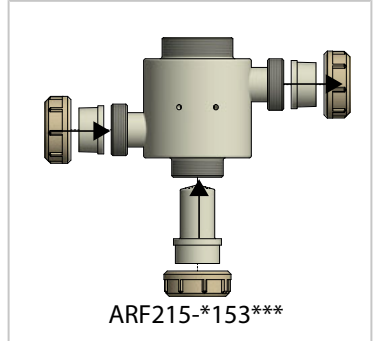
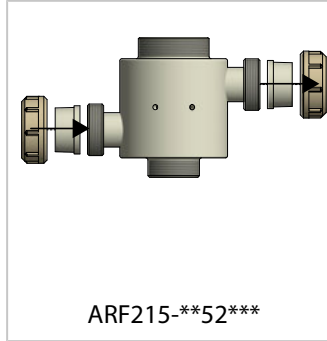
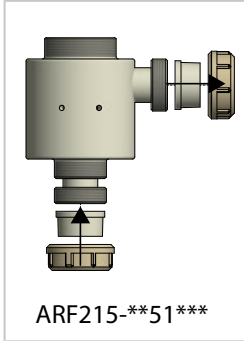

DN25/ANSI 1" flange process connection:

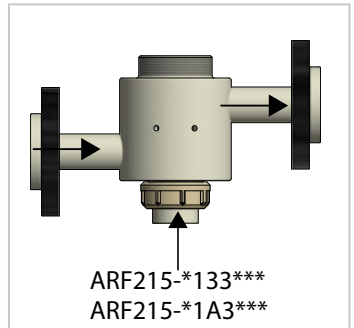
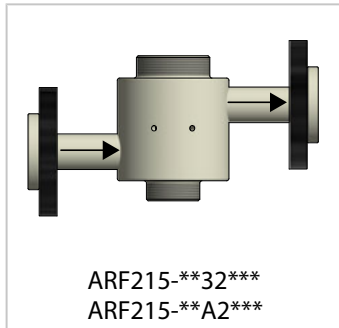
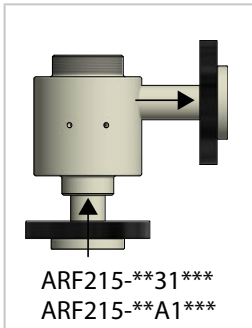
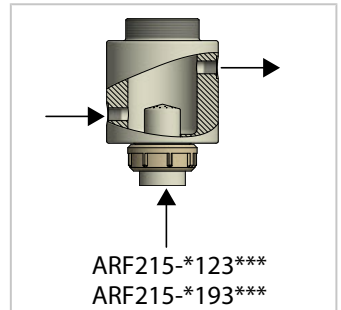
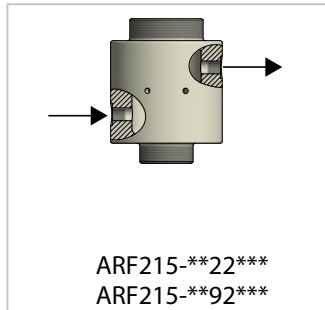
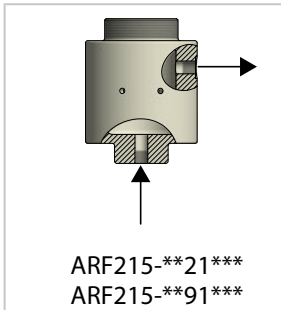
G $\frac{1}{4}$ " / $\frac{1}{2}$ " NPT threaded coupling process connection:

Sensor Adapters

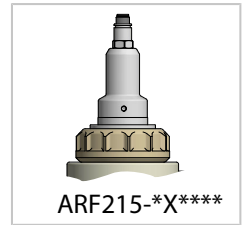
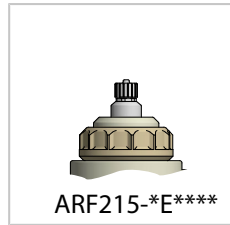
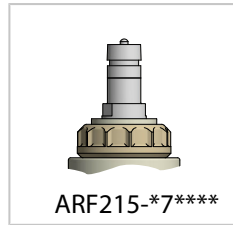
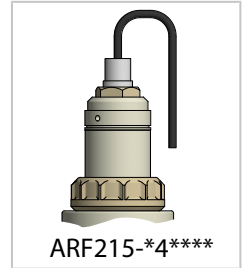
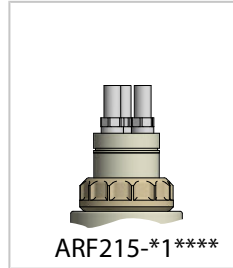
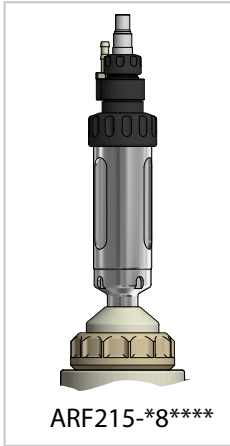

Sensor Adapters with Protective Caps

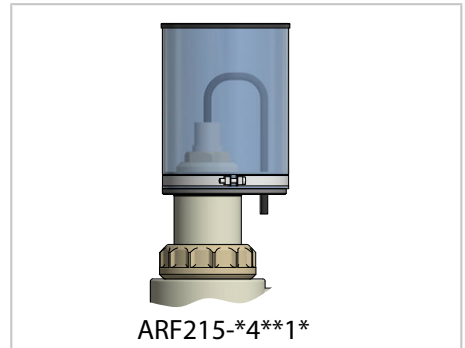
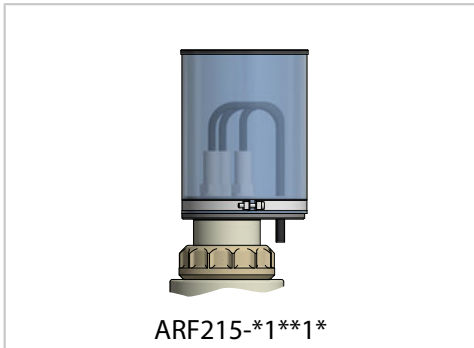

2.7 Installation Position

The ARF215 is designed for vertical installation of the sensor.

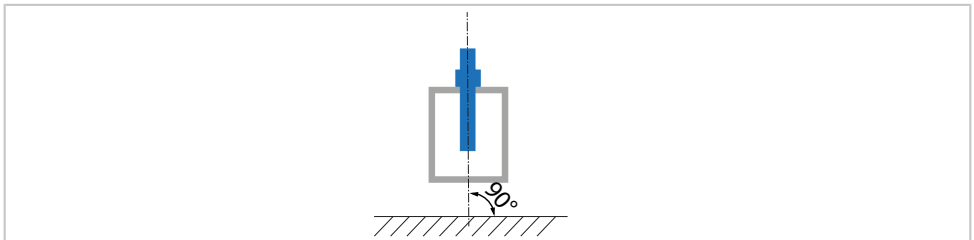

3 Installation

3.1 General Installation Instructions

Note: Operating companies must design and calculate process connections in accordance with specifications. They must specify the tightening procedures and the tightening torques/forces of the screws.

- Ensure that flange surfaces are clean, undamaged, and level. Radial surface damage such as score or impact marks is not permitted.
- The threads of screws and nuts/coupling nuts must be clean and undamaged.
- Ensure that O-rings are clean, undamaged, and dry. Adhesives and assembly pastes are not permitted for O-rings.

3.2 Installation with Threaded Coupling Process Connection

Note: Installation of the ARF215 flow-through fitting requires in-line pipe connections without center offset.

01. Position pipe ends with coupling nuts in line with the threaded coupling.
02. Tighten the coupling nuts up to the stop.

3.3 Installation with Flange Process Connection

Note: Installation of the ARF215 flow-through fitting requires in-line pipe connections without center offset.

01. Manually pre-install the screws. Insert the screws so that all the screw heads are located on one flange side.
02. Tighten the screws crosswise with 30% of the nominal tightening torque.
03. Then tighten them all with the full tightening torque.

3.4 Installation with Female Thread Process Connection

Note: Installation of the ARF215 flow-through fitting requires in-line pipe connections without center offset.

01. Place the pipe with suitable male thread in line with the female thread and tighten.

3.5 Wall Mounting

Mount the back of the ARF215 on walls or other suitable surfaces.

Note: Holder (1) can also be mounted on the front of the ARF215.

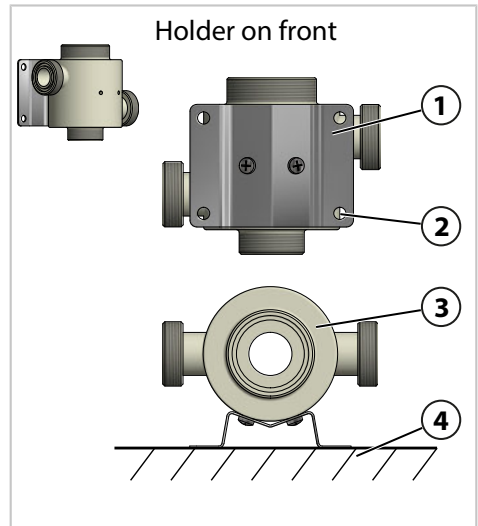
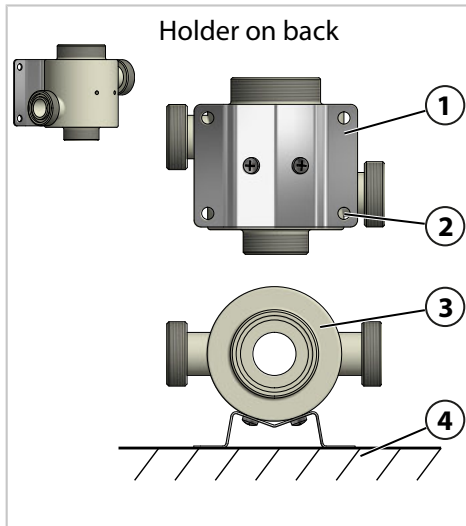

01. Mount the ARF215 (3)¹⁾ on a wall (4).

02. Use the fixings (2). Dimensions: → *Dimension Drawings, p. 34*

¹⁾ Illustration with view of holder.

3.6 Sensor Adapter Installation

Sensor Adapter 3 x PG 13.5

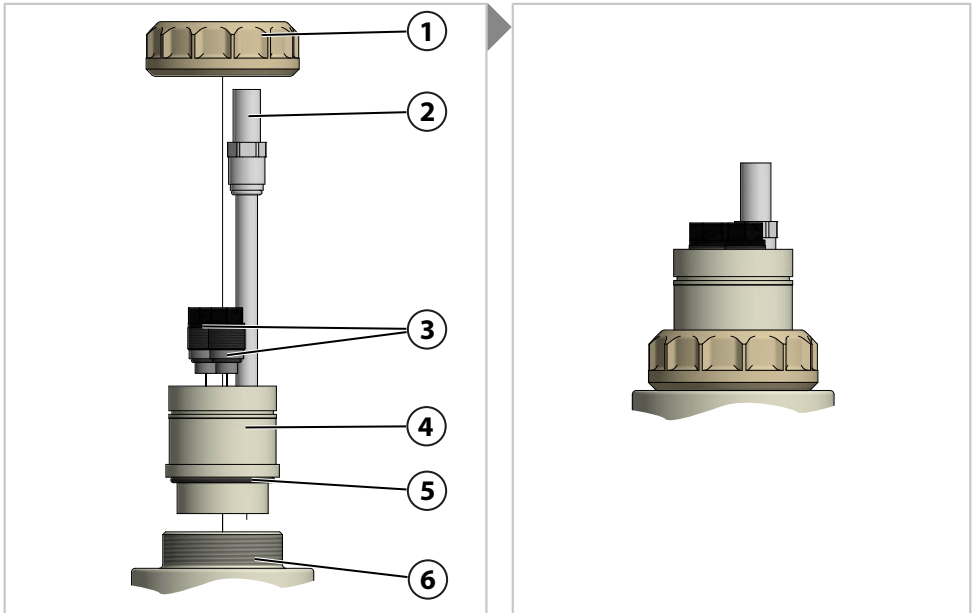

01. Check the sensor **(2)**, pressure screws **(3)**, and O-ring 48 x 3 mm **(5)** for damage.
02. Fit the O-ring 48 x 3 mm **(5)** on the adapter **(4)**.
03. Fit the adapter **(4)** in the ARF215 flow-through fitting **(6)**.
04. Fit the sensor **(2)** in the adapter **(4)**.

Note: Up to 3 sensors with \varnothing 12 mm, length approx. 120 mm, and PG 13.5 can be used. Seal off unused openings with pressure screws **(3)**.

05. Tighten the coupling nut **(1)**.
06. Connect the sensor cable.

SE660 Sensor Adapter

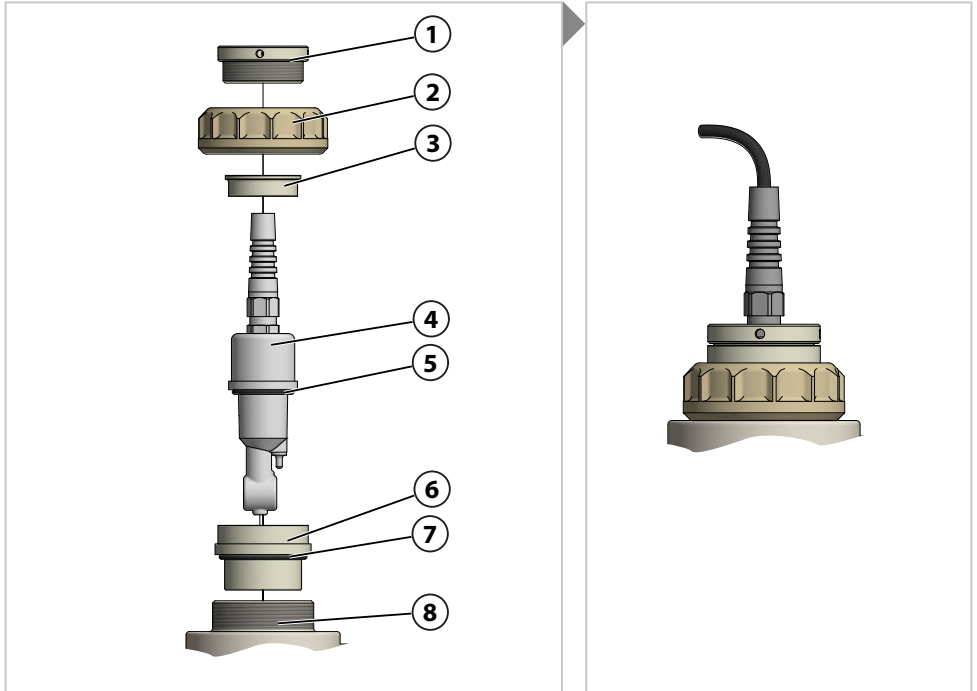

01. Check the sensor **(2)** and O-rings 33 x 3.5 mm **(5)** 48 x 3 mm **(7)** for damage.
02. Fit the 33 x 3.5 mm O-ring **(5)** on the inside and the 48 x 3 mm O-ring **(7)** on the outside of the adapter **(6)**.
03. Fit the sensor **(4)** and compression ring **(3)** in the adapter **(4)**.
04. Fit pre-assembled components in the ARF215 flow-through fitting **(8)** and screw tight with the coupling nut **(2)**.
05. Insert the pressure screw **(1)** and screw it tight with a size 58-62 hook wrench.
06. Connect the sensor cable.

SE655/SE656 Sensor Adapter

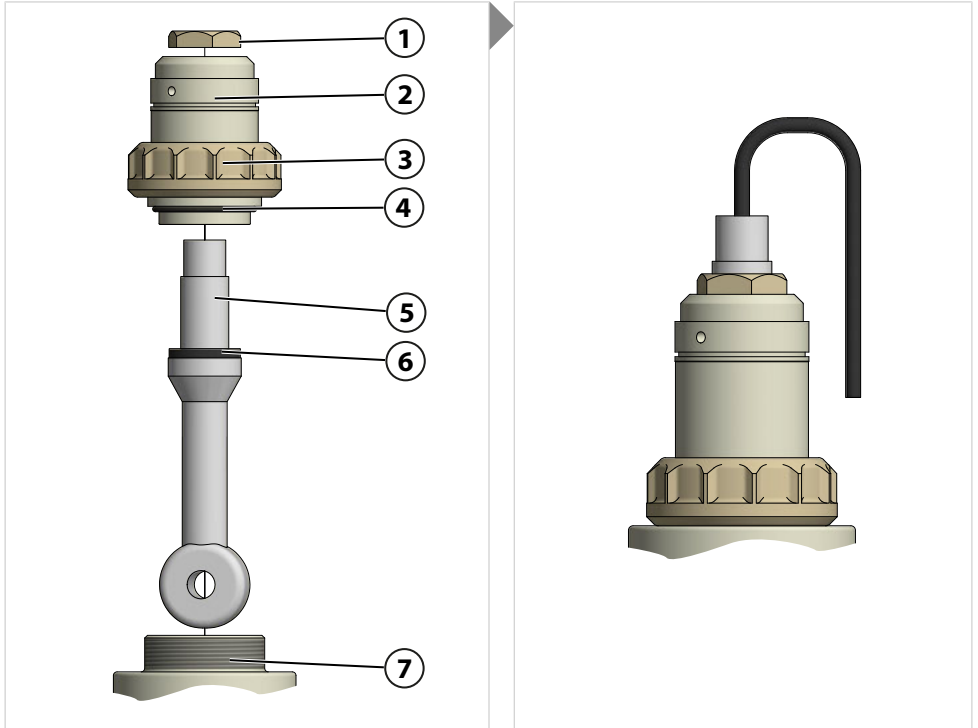

01. Check the sensor **(5)**, O-ring 48 x 3 mm **(4)**, and O-ring 30 x 2.5 mm **(6)** for damage.
02. Fit the O-ring 48 x 3 mm **(4)** on the adapter **(2)**.
03. Fit the O-ring 30 x 2.5 mm **(6)** on the sensor **(5)**.
04. Fit the sensor **(5)** in the adapter **(2)**.
05. Using the nut A/F 36 **(1)**, tighten the sensor **(5)**.
06. Fit the adapter **(2)** with sensor **(5)** in the ARF215 flow-through fitting **(7)**.
07. Tighten the coupling nut **(3)**.
08. Connect the sensor cable.

SE604/SE605/SE630 Sensor Adapter

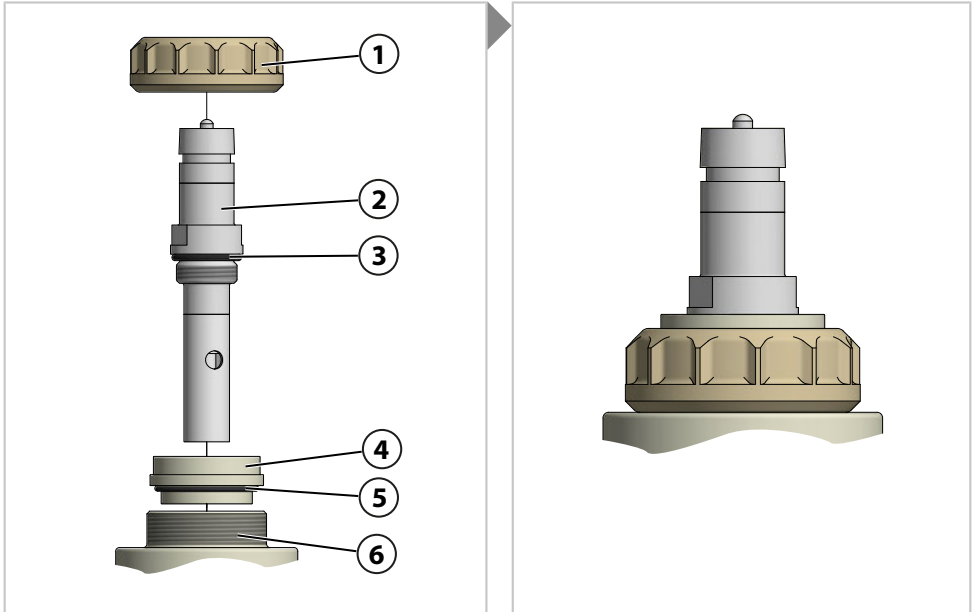

01. Check the sensor **(2)**¹⁾, O-ring 30 x 4 mm **(3)**, and O-ring 48 x 3 mm **(5)** for damage.
02. Fit the O-ring 48 x 3 mm **(5)** on the adapter **(4)**.
03. Fit the adapter **(4)** in the ARF215 flow-through fitting **(6)**.
04. Fit the sensor **(2)** with installed O-ring 30 x 4 mm **(3)** in the adapter **(4)**.
05. Tighten the coupling nut **(1)**.
06. Connect the sensor cable.

¹⁾ SE604 sensor shown only.

Liquid-Electrolyte Sensor Adapter

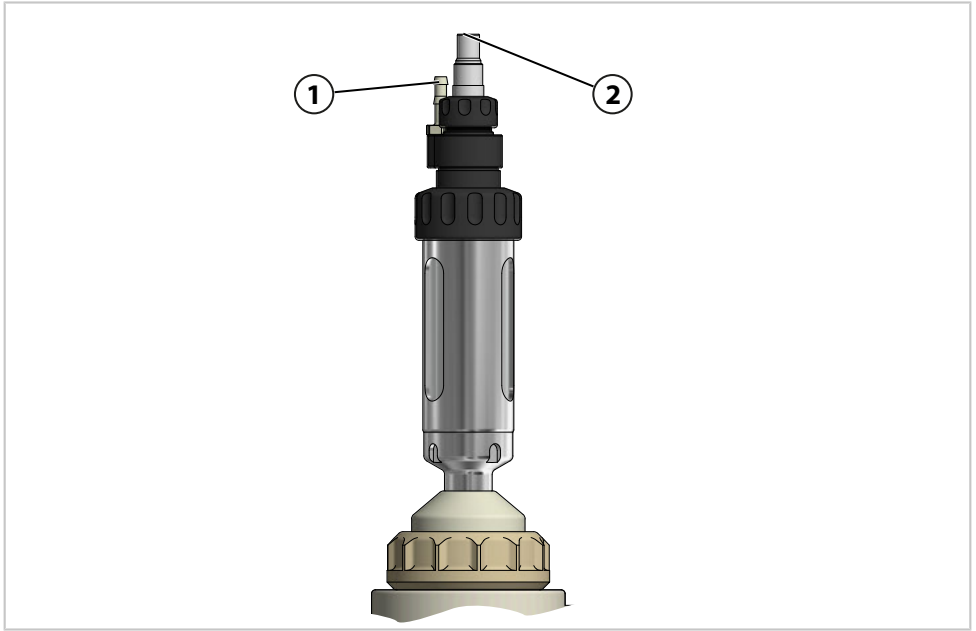

Note: The ARF215-*8**** flow-through fitting is supplied with an installed sensor adapter.

01. Connect the compressed air supply to the connection nozzle **(1)**.
02. Install the sensor **(2)**. → *Liquid-Electrolyte Sensor*, p. 25
03. Connect the sensor cable.

SE670/G1 Sensor Adapter

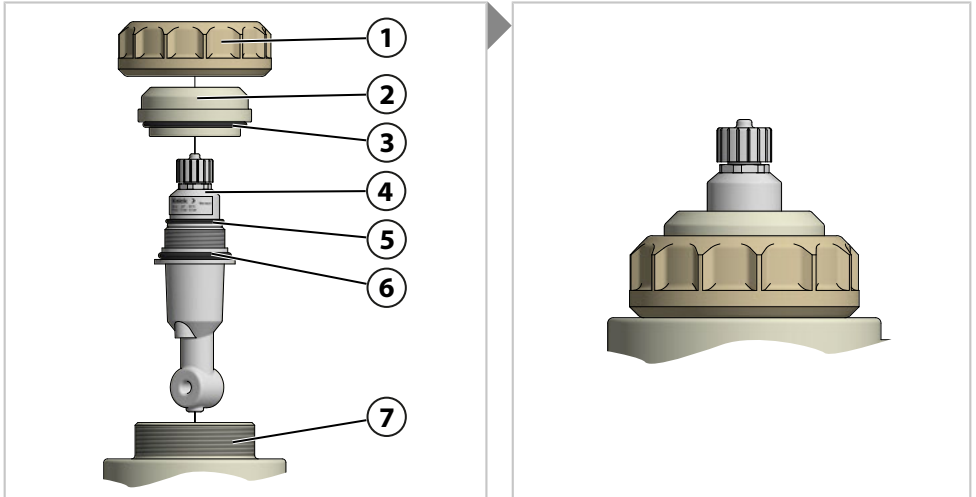

01. Check the sensor **(4)**, O-ring 48 x 3 mm **(3)**, O-ring 26 x 1.5 mm **(5)**, and O-ring 38 x 2.5 mm **(6)** for damage.

02. Fit the O-ring 48 x 3 mm **(3)** on the adapter **(2)**.

03. Fit the O-ring 26 x 1.5 mm **(5)** and O-ring 38 x 2.5 mm **(6)** on the sensor **(4)**.

Note: Check the O-rings **(5)** and **(6)** for correct positioning.

04. Screw the sensor **(4)** into the adapter **(2)**.

05. Fit the adapter **(2)** in the ARF215 flow-through fitting **(7)**.

06. Tighten the coupling nut **(1)**.

07. Connect the sensor cable.

SE680 Sensor Adapter

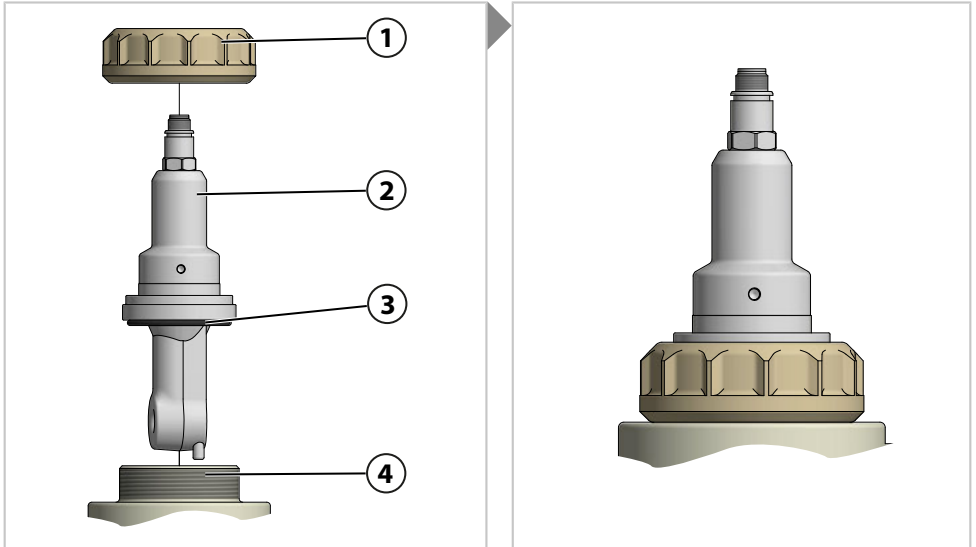

01. Check the sensor **(2)** and O-ring 51 x 3 mm **(3)** for damage.
02. Fit the O-ring 51 x 3 mm **(3)** on the sensor **(2)**.
03. Fit the sensor **(2)** in the ARF215 flow-through fitting **(4)**.
04. Tighten the coupling nut **(1)**.
05. Connect the sensor cable.

3.7 Protective Cap Installation

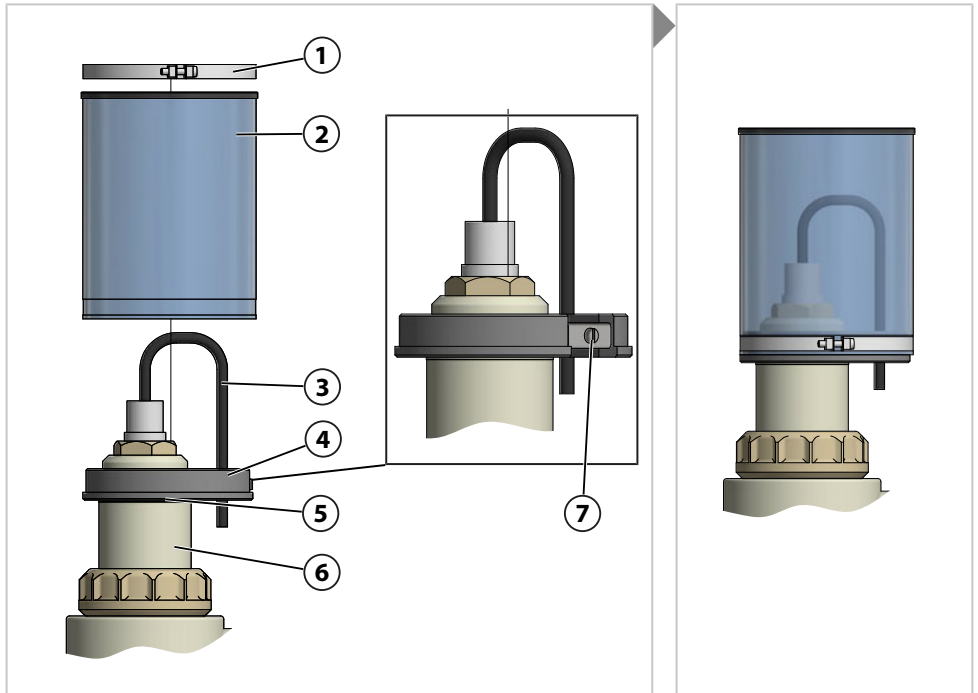

01. Check the O-ring 48 x 3 mm (5) for damage.

Note: Flange (4) is pre-installed on adapter (6).

02. Fit the cap (2) on the flange (4).

03. Guide the sensor cable (3) through the cable fastening (7) and screw it tight.

04. Place the pipe clamp (1) over the cap (2) and screw it tight.

3.8 Pressure and Leak Test

Note: Pressure and leak tests must be carried out in accordance with the relevant operating regulations or the operating company's instructions.

01. Check the process connections for leaks.

02. Check the sensor adapter for leaks.

03. Observe the specification limits during pressure testing. → *Specifications, p. 32*

4 Commissioning

⚠ WARNING! Process medium may leak from the ARF215 in the event of damage or improper installation, and may contain hazardous substances. Follow the safety instructions. → *Safety, p. 5*

Note: Upon request, Knick Elektronische Messgeräte GmbH & Co. KG will provide safety instruction and product training during initial commissioning of the product. More information is available from the relevant Knick representatives.

01. Install the ARF215. → *Installation, p. 12*
02. Mount the bracket securely.
03. Install the sensor adapter and sensors. → *Sensor Adapter Installation, p. 14*
04. Optional: Connect the cleaning connection.
05. Optional: Connect the compressed air supply for liquid-electrolyte sensors.
→ *Liquid-Electrolyte Sensor Adapter, p. 18*
06. Check the ARF215 for leaks under process conditions. → *Pressure and Leak Test, p. 21*
 - ✓ The ARF215 and connections have no leaks.

5 Operation

5.1 General Notes on Operation

Operation of the ARF215 is maintenance-free. The process, however, may require the sensors to be replaced or removed for cleaning or calibration during operation of the ARF215.

For further information, refer to the applicable documentation of the sensor manufacturer.

5.2 Safety Instructions on Installing and Removing Sensors

⚠ WARNING! Process medium, potentially containing hazardous substances, may escape from the ARF215. Depressurize the area, block the pipe system (no process medium in the area of the fitting), and, as required, rinse the pipe system. Do not install damaged sensors.

⚠ CAUTION! Risk of cutting injuries from broken sensor glass. Handle the sensor with care. Follow the safety instructions in the sensor manufacturer's documentation.

5.3 Sensor: Installation and Removal

Sensor Diameter 12 mm, Length approx. 120 mm, and PG 13.5

Installation

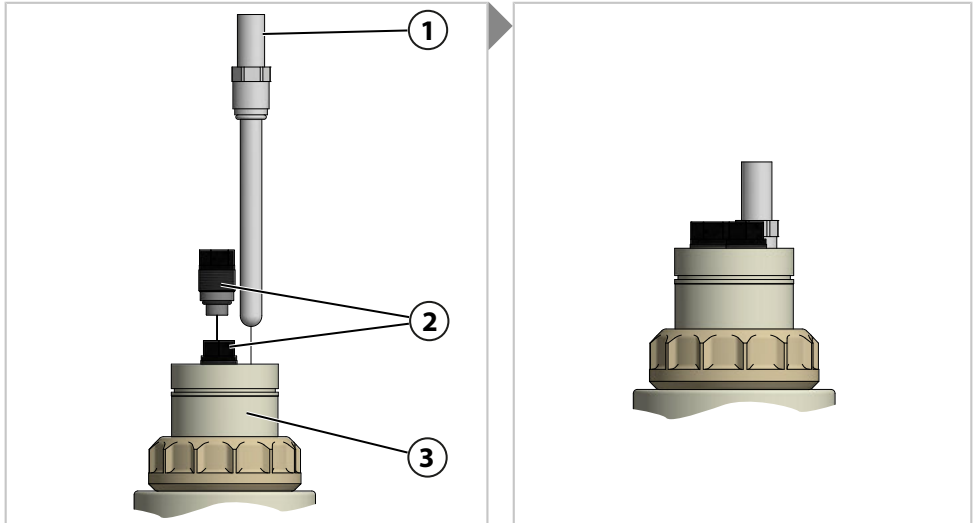

01. Check to ensure that the sensor **(1)** is suitable for use.

- ✓ Diameter 12.0 mm
- ✓ Length approx. 120 mm
- ✓ Pressure resistance permissible for process → *Specifications, p. 32*

02. Check the sensor **(1)** for damage.

Note: Do not install or commission damaged sensors or O-rings.

03. Push the sensor **(1)** into the adapter **(3)**.

Note: Seal off unused sensors openings with a pressure screw **(2)**.

04. Screw the sensor tight.

05. Connect the sensor to the sensor cable, the sensor cable to the analyzer.

06. Test for leaks.

Removal

01. Disconnect the sensor **(1)** from the sensor cable, the sensor cable from the analyzer.

02. Loosen the sensor **(1)** and remove it from the adapter **(3)**.

Liquid-Electrolyte Sensor

Installation

Note: To ensure that the electrolyte flows from the reference electrode to the process medium, the air pressure in the pressure chamber must be 0.5 to 1 bar above that of the process medium.

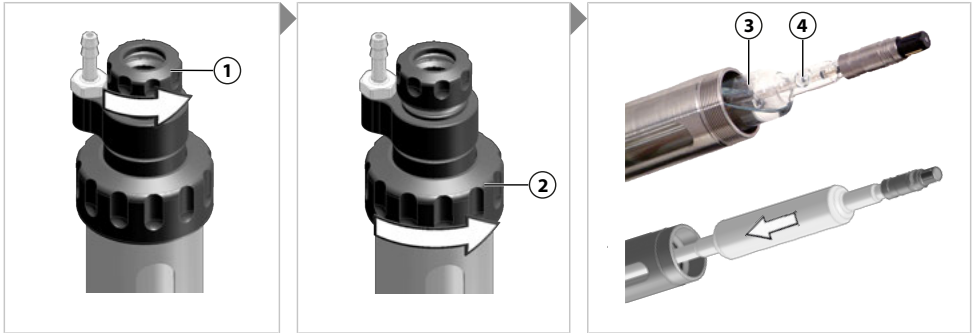

01. Loosen the small coupling nut **(1)** by a few rotations; do not loosen completely.
02. Fully loosen the large coupling nut **(2)** and pull off the entire unit.
03. Remove the watering cap from the sensor tip and rinse the sensor **(3)** with water.
04. Remove the cap of the filling hole **(4)** of the sensor **(3)**.
05. Push in the sensor **(3)**.

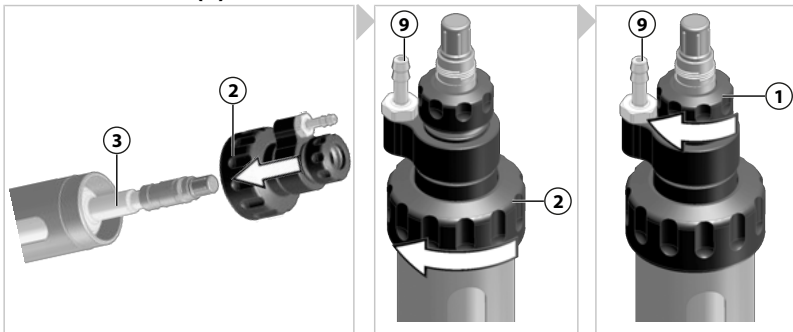

06. Position the large coupling nut **(2)** and fasten finger tight.
07. Fasten the small coupling nut **(1)** finger tight.
08. Connect the sensor to the sensor cable, the sensor cable to the analyzer.
09. On first-time installation: Connect the air pressure inlet for the pressure chamber to the connection nozzle **(9)**.

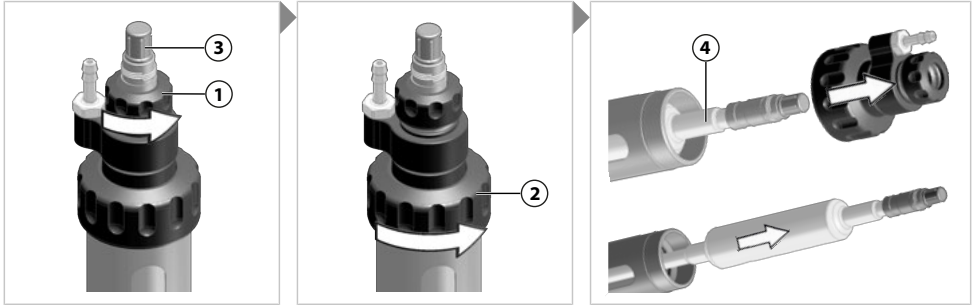
Removal

01. Disconnect the sensor cable from the sensor head **(3)**.

02. Loosen the small coupling nut **(1)** by a few rotations; do not loosen completely.

03. Fully loosen the large coupling nut **(2)** and pull off the entire unit.

Note: Hold the sensor's filling hole upward at an inclined angle during removal to prevent electrolyte from escaping. Follow the instructions in the sensor manufacturer's documentation. During transport and storage, close the sensor's filling hole with the cap.

04. Pull out the sensor **(4)**.

05. If the sensor glass is broken, check the sensor holder O-rings for damage and replace them if necessary.

Conductivity Sensor

Installation

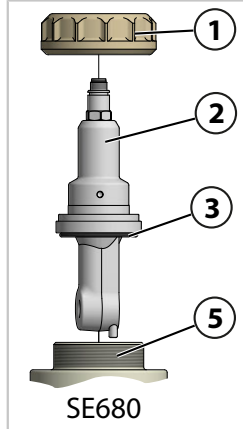
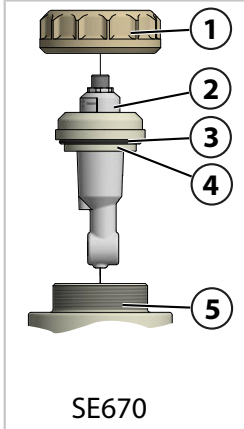
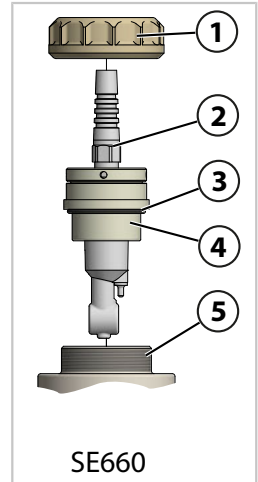
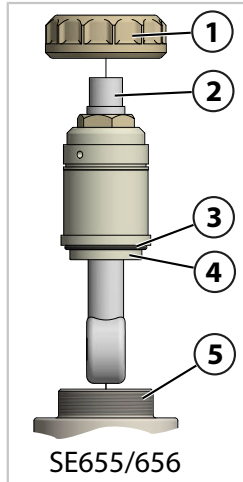
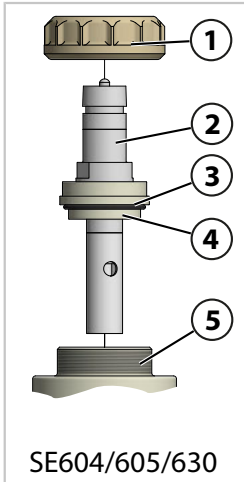

01. Check the sensor (2) and O-ring (3) for damage.

Note: Do not install or commission damaged sensors or O-rings.

02. Fit the sensor (2) with adapter (4), if provided, in the ARF215 (5).

03. Connect the sensor (2) to the sensor cable and the sensor cable to the analyzer, if applicable.

04. Test for leaks.

✓ The sensor (2) is mechanically installed.

Removal

01. Disconnect the sensor **(2)** from the sensor cable and the sensor cable from the analyzer, if applicable.
02. Pull out the sensor **(2)** with adapter **(4)**, if provided.

6 Maintenance

6.1 Sensor Inspection and Maintenance

Information on inspection and maintenance can be found in the user manuals of the installed sensors.

For further information, refer to the applicable documentation of the sensor manufacturer.

6.2 Knick Premium Service

Knick offers individually compiled services tailored to the customer's requirements for inspections and functional tests on the product.

Further information can be found at www.knick.de.

7 Troubleshooting

Malfunction state	Possible remedies
Process medium leakage	<p data-bbox="479 225 684 252">Loose flange option:</p> <p data-bbox="479 252 680 279">Fully tighten screws.</p> <p data-bbox="479 279 770 306">Check flange bushing O-ring.</p> <hr/> <p data-bbox="479 320 745 347">Check threaded couplings.</p> <hr/> <p data-bbox="479 362 1025 416">Properly secure the coupling nut of the sensor adapter and/or the cable gland.</p> <hr/> <p data-bbox="479 430 779 458">Screw in sensor(s) completely.</p> <hr/> <p data-bbox="479 472 639 499">Check sensor(s).</p> <hr/> <p data-bbox="479 513 829 541">Check condition of sensor material.</p> <hr/> <p data-bbox="479 555 835 582">Check condition of sensor O-ring(s).</p> <hr/> <p data-bbox="479 596 829 624">Check condition of O-ring material.</p> <hr/> <p data-bbox="479 638 824 665">Check condition of fitting material.</p>
Axial protrusion of sensor	Screw in sensor completely.
Protruding sensor adapter	Comply with temperature/pressure values.
Rinse medium leakage	<p data-bbox="479 746 1014 774">Rinse function option: Correctly connect rinsing hose.</p> <p data-bbox="479 788 670 815">Check rinsing hose.</p>

8 Decommissioning

8.1 Flow-Through Fitting: Removal

Note: Obtain approval from the operating company prior to commencing removal of the flow-through fitting. Adhere to the on-site safety regulations.

▲ WARNING! Process medium, potentially containing hazardous substances, may escape from the ARF215. Depressurize the area, block the pipe system (no process medium in the area of the fitting), and, as required, rinse the pipe system.

01. Depressurize the process.
02. Disconnect the sensor cable from the sensor/analyzer.
03. Disconnect the process connections.
04. Seal off the process ports appropriately.
05. Disconnect the ARF215 flow-through fitting from the mount.

8.2 Returns

If required, send the product in a clean condition and securely packed to your local contact. → knick.de

If there has been contact with hazardous substances, the product must be decontaminated or disinfected prior to shipment. The consignment must always be accompanied by a corresponding return form to prevent service employees being exposed to potential hazards.

8.3 Disposal

The local codes and regulations must be observed when disposing of the product.

The ARF215 can contain various materials, depending on the version concerned.

→ *Product Code, p. 7*

9 Specifications

Note: Thermoplastics have temperature-dependent mechanical properties. Observe these properties when selecting components.

Material process-wetted	
Flow cell	PP-H / PVDF
Adapter	PP-H / PVDF
Gaskets	EPDM / FKM / FFKM
Material non-process-wetted	
Protective cap	PVC
Wall holder	1.4571
Cable clamp	1.4571 / EPDM
Sensor insertion position	Vertical
Process medium flow	
Clean media ¹⁾	10 l/h...200 l/h
Soiled media ²⁾	10 l/h...2000 l/h
Residual volume	approx. 150 ml
Installation factor ³⁾	approx. 1.08
Ambient temperature	-5...50 °C (23...122 °F)
Process temperature	
PP-H	0...90 °C (32...194 °F)
PVDF	-20...120 °C (-4...248 °F)
Process pressure	
PP-H	
40° C (104° F)	6 bar (87 psi)
90° C (194° F)	1.5 bar (22 psi)
PVDF	
100° C (212° F)	6 bar (87 psi)
120° C (248° F)	3 bar (44 psi)

¹⁾ Applies to G¼" process connection.

²⁾ Applies to DN25 process connection.

³⁾ Applies only to installed SE655 or SE656 conductivity sensor.

Pressure/Temperature Diagram

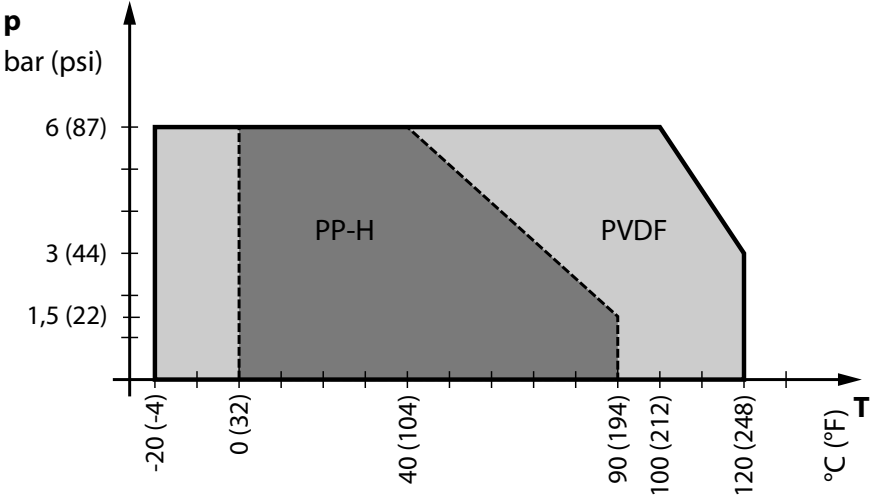

10 Dimension Drawings

Flow-Through Fitting

Note: All dimensions are given in millimeters [inches].

DN25 Threaded Coupling Process Connection

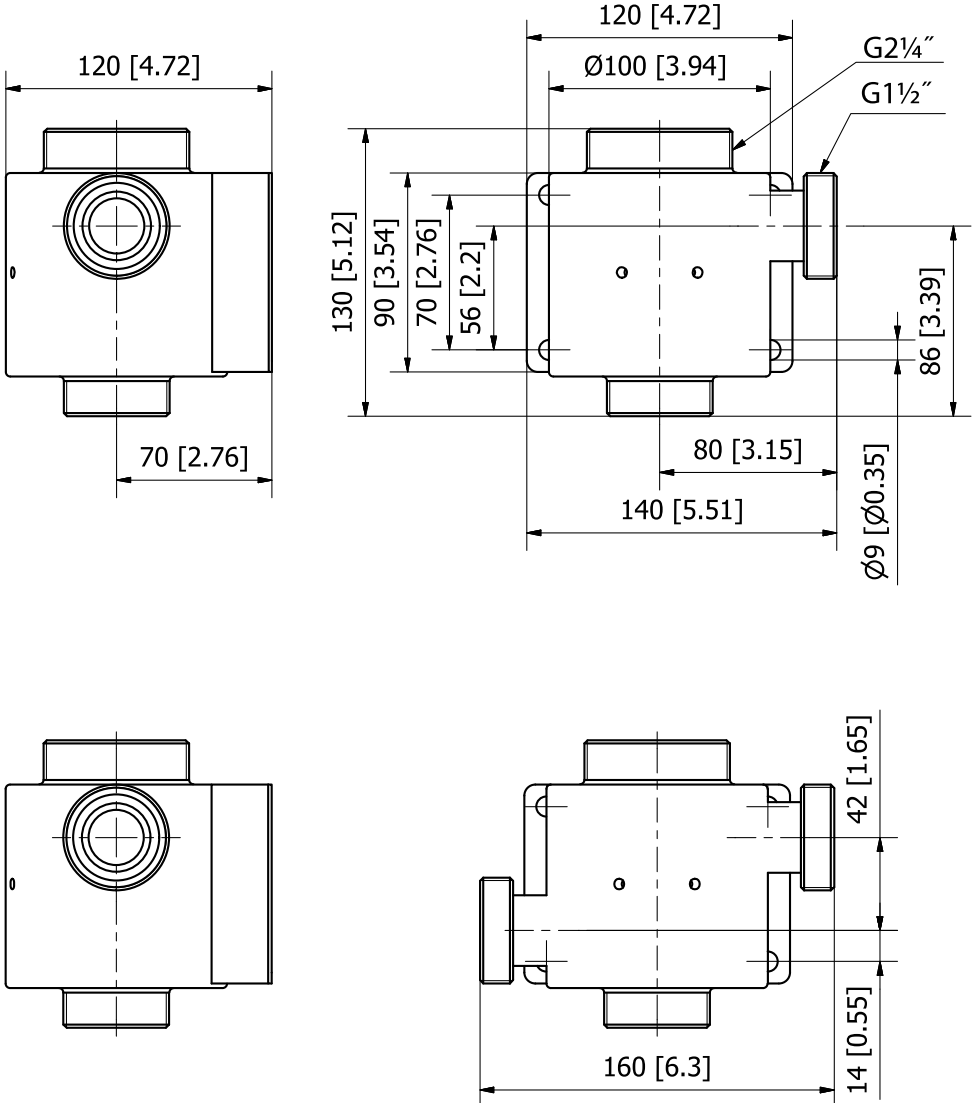

DN25/ANSI 1" Flange Process Connection

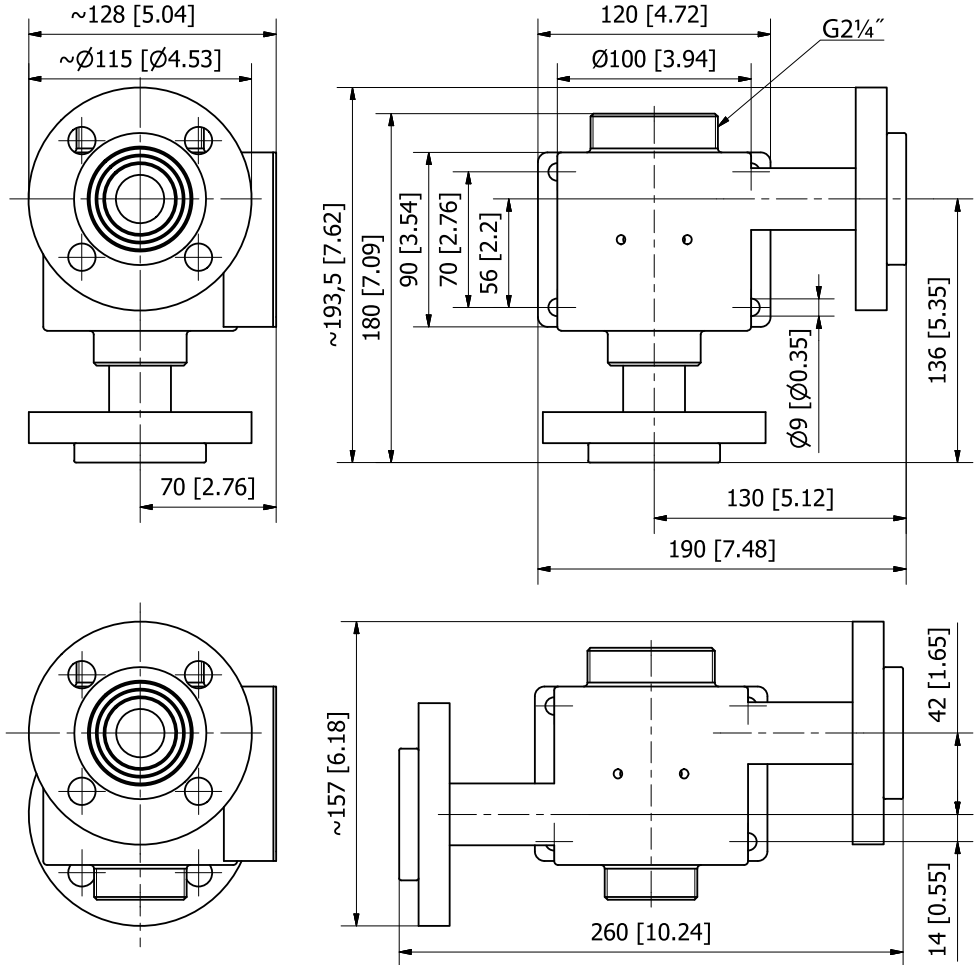

G $\frac{1}{4}$ " / $\frac{1}{2}$ " NPT Female Thread Process Connection

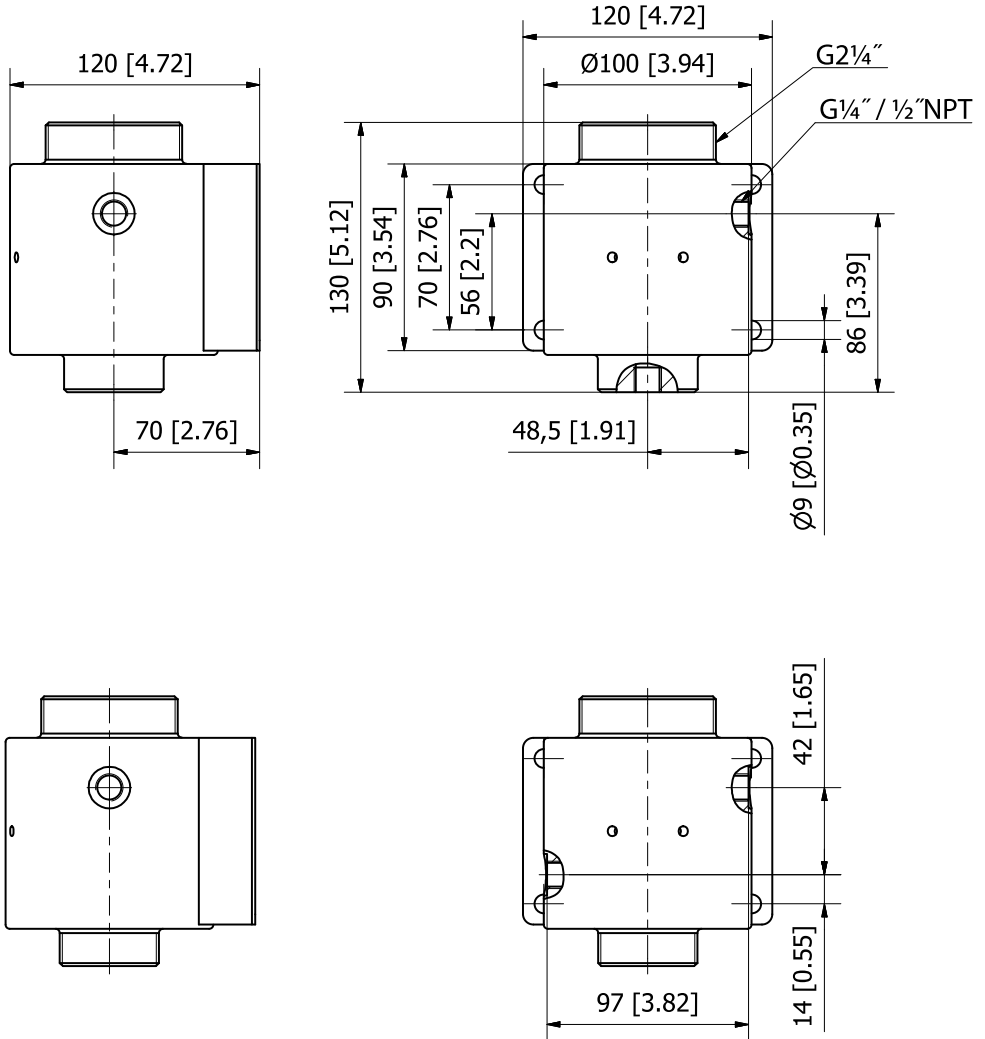

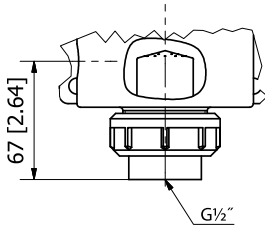

Cleaning connection with 18 nozzles (only with 180° process arrangement and sensor adapter 3 x PG 13.5)

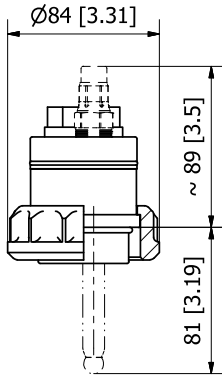

Sensor adapter 3 x PG13.5 without protective cap

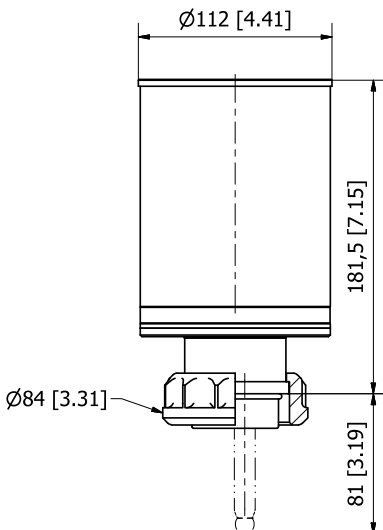

Sensor adapter 3 x PG13.5 with protective cap

SE660 sensor adapter

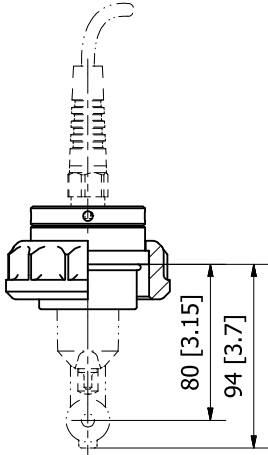

SE655 / SE656 sensor adapter without protective cap

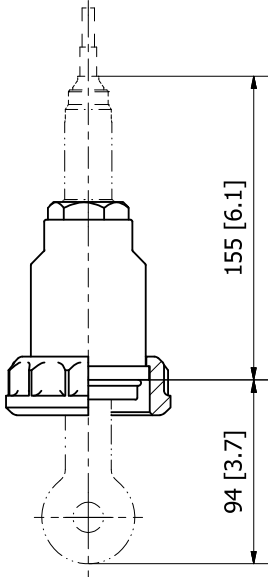

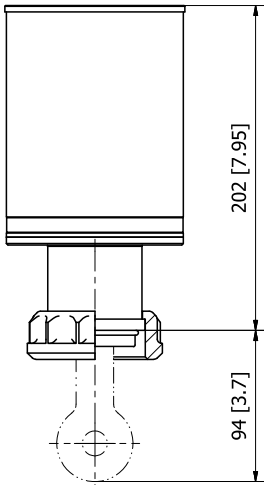

SE655 / SE656 sensor adapter with protective cap

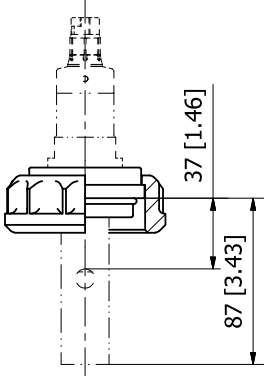

SE604 sensor adapter

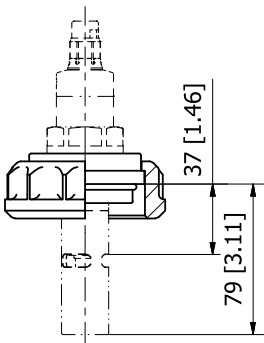

SE605 sensor adapter

SE630 sensor adapter

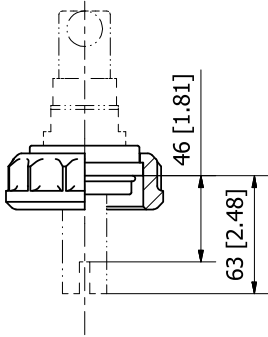

Sensor adapter for pH sensor, Ø 12 mm, pressurized

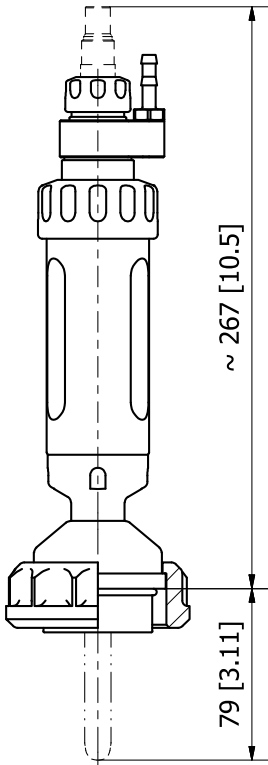

SE670 sensor adapter

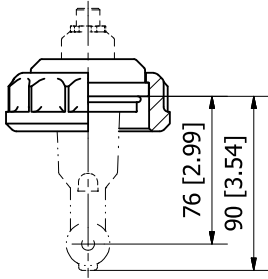

SE680 sensor adapter

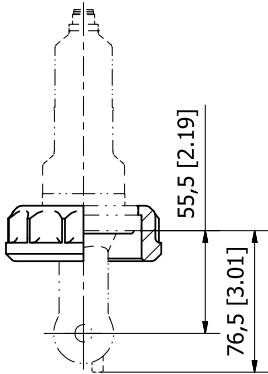

Appendix

→ Return Form, p. 43

Return Form

Declaration of potential hazards in the enclosed products from exposure to hazardous substances* or mixtures

* Classification preferably according to CLP regulation

We can only accept and carry out the service order if this declaration is filled out completely.

Please include it with the shipping documents.

If you have any questions, please contact our repairs department in Berlin.

RMA number (can be obtained by calling +49 30 80 191-241):

Customer information (must be completed if no RMA number is available):

Company:

Address:

Contact: Tel./Email:

Information on the product:

Product name:

Serial number:

Included accessories:

- The product being returned is new/unused.
- The product has not been exposed to hazardous substances or mixtures.
- The product has been exposed to hazardous substances or mixtures.

State the classification of the hazardous substance, as applicable together with the hazard statements (or R-phrases), or at minimum provide the relevant hazard pictograms:

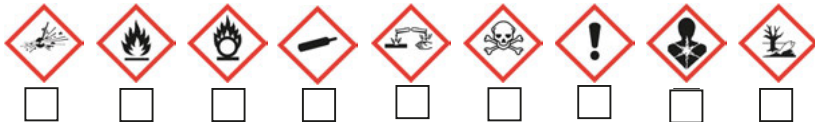

- The product has been exposed to infectious substances.
- The product was subjected to suitable cleaning procedures to prevent exposure to hazards prior to return.
- The product was not freed of hazardous substances prior to return.

I have answered the above questions to the best of my knowledge.

Name: Company:

Date: Signature:

Copyright 2019 • Subject to change
This document was published on September 20, 2019.
The latest documents are available for download on our website.

Knick
Elektronische Messgeräte
GmbH & Co. KG
Beuckestraße 22, 14163 Berlin,
Germany
Phone: +49 30 80191-0
Fax: +49 30 80191-200
info@knick.de • www.knick.de



Declaration of Contamination



Knick
Elektronische Messgeräte
GmbH & Co. KG

Headquarters

Beuckestraße 22 • 14163 Berlin
Germany
Phone: +49 30 80191-0
Fax: +49 30 80191-200
info@knick.de
www.knick.de

Local Contacts

www.knick-international.com

Translation of the original instructions
Copyright 2021 • Subject to change
Version 02 • This document was published on April 19, 2021.
The latest documents are available for download on our
website under the corresponding product description.

TA-802.400-KNEN02



098593