



## SensoGate WA 132

**Pneumatic Retractable Fitting with Maximum Resistance**

### One Solution for Any Application.

SensoGate revolutionizes the conventional principle of push rod fittings. Its unique modular design greatly simplifies both initial installation and the later replacement of wear parts. The patented lock-gate principle reliably prevents leakage of process medium during probe movement. Highly efficient cyclone rinsing ensures effective cleaning of the sensor.

The new SensoGate WA 132 combines the pioneering benefits of the SensoGate WA 130 series with the unrivaled chemical resistance of PTFE.

The result is a PTFE retractable fitting with the variability and modularity of the SensoGate concept.

### Versions

Two different immersion depths and the use of sensors with gel or liquid filling enable universal use. DIN and ANSI flanges in various sizes are used for the process connection. Custom versions for PFA-lined sight glasses are also available.

### Universal and Modular

Sensors with a PG 13.5 connecting thread and a length of 225 mm or liquid-filled sensors with a length of 250 mm can be used. The modular concept makes it easy to replace the PTFE immersion tube in just a few steps. The split calibration chamber facilitates replacement of the gaskets, e.g., during maintenance work.

# SensoGate WA 132

## Fully Automated, Systematic Liquid Analysis

Combining the SensoGate WA 132 retractable fitting with the Uniclean (cleaning) or Unical (cleaning and calibration) control units and the Protos measuring system makes it possible to implement complete, fully automatic measuring points that provide an extraordinarily high level of precision and reliability.

The system offers maximum safety by monitoring the compressed-air and water supply, the probe position, and the buffer and cleaning solution levels.

Maximum consistency and precision is ensured by a patented metering pump technology with separate routing of the media. Short-time measurements and regular cleaning ensure longer sensor lives. Neither automatic cleaning nor calibration interrupt the production process.

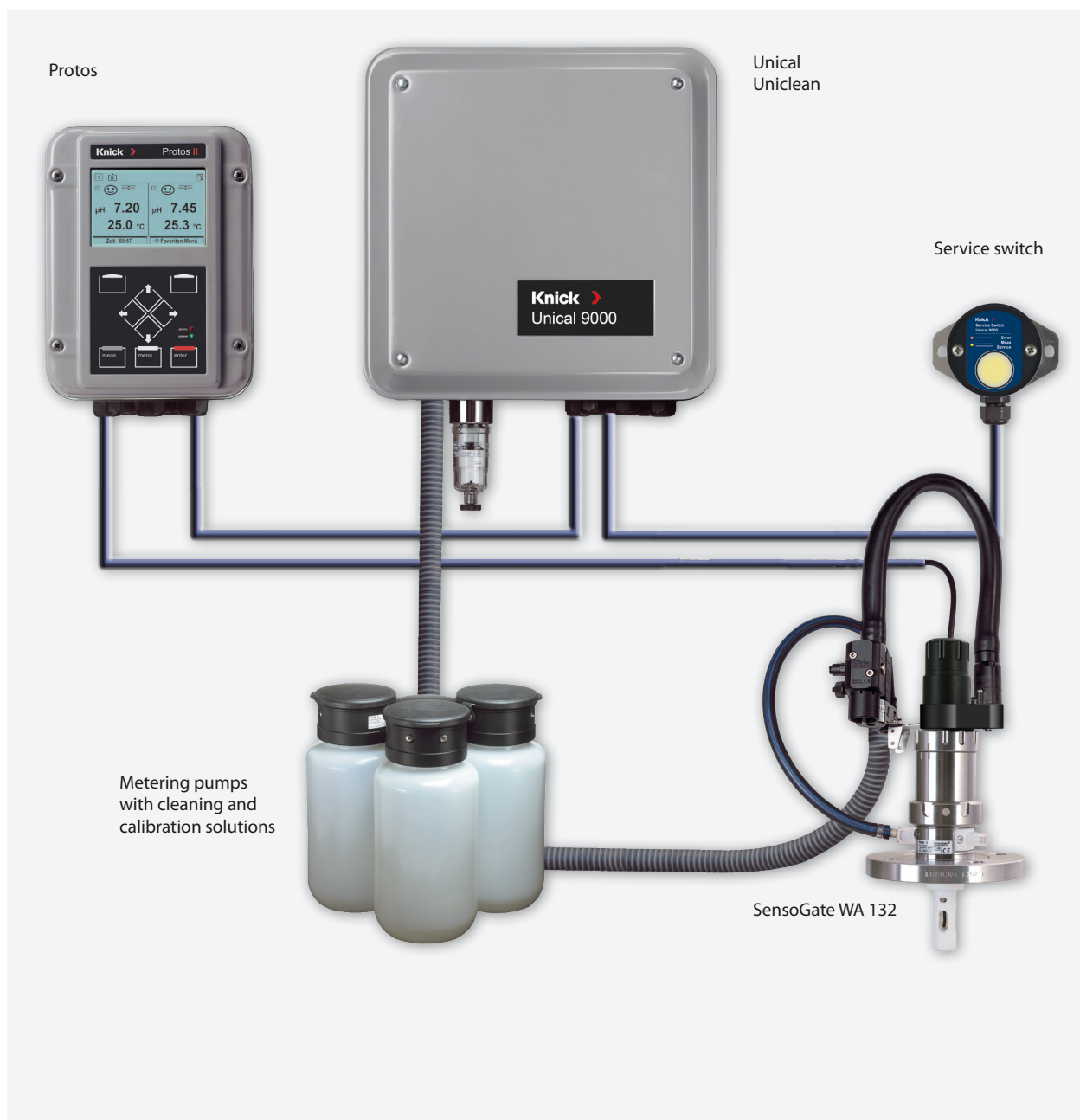

## Facts and Features

---

- Extremely high chemical resistance
- All wetted parts in PTFE:
  - anti-adhesive
  - good resistance to hot water
  - FDA-compliant
- Fully modular concept
- Easily replaceable immersion tube and calibration chamber
- PTFE calibration chamber in stainless steel frame, prevents cold flow and wear
- Cyclone rinsing – effective sensor cleaning
- Operation with PG 13.5 sensors or liquid-filled sensors
- Operation with Unical 9000/Uniclean 900
- Pneumatic or manual operation
- Optimal operation with lined fittings

## Process Connections

---

- EN 1092-1 flanges from DN 32
- ANSI B 16.5 flanges from 1.5"
- Flange bushings for sight glasses acc. to DIN 3237 Part 2 from DN 40

# SensoGate WA 132

## Specifications

Permissible process pressure and temperature	6 bar (at 0 ... 40 °C) 6 bar (40 °C), falling linearly to 3 bar (100 °C) 3 bar (max. 1 hour) at 135 °C	
Ambient temperature	- 10 ... +70 °C	
Protection	IP66	
Housing material	Stainless steel/PP or PEEK	
Permissible pressure for probe control	4 ... 7 bar	
Quality of compressed air	Standard	According to ISO 8573-1:2001
	Quality class	3.3.3 or 3.4.3
	Solid contaminants	3 (max. 5 µm, max. 5 mg/m <sup>3</sup> )
	Water content for temperatures > 15 °C	Class 4, pressure dew point 3 °C or below
	Water content for temperatures 5 ... 15 °C	Class 3, pressure dew point -20 °C or below
	Oil content	Class 3 (max. 1 mg/m <sup>3</sup> )
Sensors	with solid electrolyte	Ø 12 mm, length 225 mm, PG 13.5 thread
	with liquid electrolyte	Ø 12 mm, length 250 mm
Process connections	Flanges, EN 1092-1	DN 32 to DN 100
	Flanges, ANSI B 16.5	1½" to 3"
	Flange bushings, for sight glasses acc. to DIN 3237 Part 2	from DN 40
Connections	Inlet	Via Unical multiplug
	Outlet	PFA hose coupling for hose, Ø8×1 mm
	For pressurized sensors	Hose connection NW 6 mm, pressure in calibration chamber 0.5 ... 1 bar above process pressure (max. 7 bar)
	For compressed air	Via Unical multiplug (control air for retractable fitting)
Immersion depths/dimensions	See dimension drawings	
Wetted materials	PEEK (natural)	

## Specifications for Use in Hazardous Locations

EU Type Examination Certificate	KEMA 04ATEX4035X
Device	SensoGate WA 13** -X ... retractable fitting
ATEX marking of the device	II 1 G/D c II
Ambient temperature (Ex)	-10 ... +70 °C
Process pressure (Ex)	Max. 6 bar
Compressed-air supply (Ex)	4 bis 7 bar, momentarily approx. 100 l/min
Process temperature (Ex)*	0 to 120 °C (plastic) or 0 to 140 °C (steel)
Special conditions (Ex)	None

\*) Explosive atmospheres caused by gases, vapors, mists: the maximum surface temperature only depends on the process temperature at the SensoGate housing and the flange.

## Product Line

SensoGate Process Retractable Fitting		WA 132 - <input type="checkbox"/> <input type="checkbox"/> <input type="checkbox"/> <input type="checkbox"/> <input type="checkbox"/> <input type="checkbox"/> <input type="checkbox"/> <input type="checkbox"/> <input type="checkbox"/> <input type="checkbox"/> <input type="checkbox"/>																		
Explosion protection	For hazardous area - Zone 1 Without	X N																		
Sensor	Sensor, Ø12 mm, with PG 13.5 pH sensor, Ø 12 mm, with pressurization	0 1																		
Gasket material	FKM EPDM EPDM – FDA FKM – FDA FFKM – FDA FFKM	A B E F H K																		
Wetted materials*	PTFE	R																		
Process connection	Flange, loose, 1.4571, PN10/16, DN 32	B 0																		
	Flange, loose, 1.4571, PN10/16, DN 40	B A																		
	Flange, loose, 1.4571, PN10/16, DN 50	B 1																		
	Flange, loose, 1.4571, PN10/16, DN 65	B 2																		
	Flange, loose, 1.4571, PN10/16, DN 80	B 3																		
	Flange, loose, 1.4571, PN10/16, DN 100	B 4																		
	Flange, loose, ANSI 316, 150 lbs, 2"	D 1																		
	Flange, loose, ANSI 316, 150 lbs, 2 ½"	D 2																		
	Flange, loose, ANSI 316, 150 lbs, 3"	D 3																		
	Flange, loose, ANSI 316, 150 lbs, 3 ½"	D 4																		
	Fitting, DIN 3237-2, PN 16, DN 40	T A																		
	Fitting, DIN 3237-2, PN 16, DN 50	T 1																		
	Flange, loose, 1.4571, DN 40 for flat flange made of glass	U A																		
Flange, loose, 1.4571, DN 50 for flat flange made of glass	U 1																			
Immersion depth	Short	A																		
	Long	B																		
Connection	Media connection, PP	A																		
	Media connection, PEEK	B																		
	Media connection, PEEK, integr. connector for add. medium	C																		
Special variant	Without															0	0	0		
	Equipped with special grease (provided by customer)																		1	
	Customer-specific special datasheet																			F

Further configurations of these options may be available on request.

\* Material combinations: process-wetted part of calibration chamber / rinse-wetted part of calibration chamber / immersion tube

# SensoGate WA 132

## Product Line

Accessories		Order No.
Service set	Basic	ZU 0680
Sensor spanning wrench, 19 mm		ZU 0647
Bellows (version for liquid-electrolyte sensors)		ZU 0739
Protective cap (version for sensors with polymer electrolyte)		ZU 0759
Adapter for free hose connection	PP/EPDM (incl. electrical check-back)	ZU 0733
	PP/EPDM (w/o electrical check-back)	ZU 0734
	PEEK/EPDM (incl. electrical check-back)	ZU 0742
Air supply for pressurized sensors, 0.5 ... 4 bar		ZU 0670/1
Air supply for pressurized sensors, 1 ... 7 bar		ZU 0670/2
Hose, 20 m (extension for ZU 0670)		ZU 0713
<b>Check Valve</b>		RV01-
Housing material, valve body	Stainless steel 1.4404	H
	PEEK	E
Gasket material	FKM	A
	EPDM	B
	FFKM	C
	FKM FDA	F
	EPDM FDA	E
	FFKM FDA	H
Inlet connection, female thread	G $\frac{1}{4}$	4
	G $\frac{1}{8}$	8
Outlet connection, male thread	G $\frac{1}{4}$	4
	G $\frac{1}{8}$	8
<b>Gaskets</b>		
Set	Contact (process/rinse medium)	Order No.
A/1	FKM	ZU 1016/1
A/2	FKM / FKM	ZU 1016/2
B/1	EPDM	ZU 1017/1
B/2	EPDM / EPDM	ZU 1017/2
E/1	EPDM FDA	ZU 1018/1
E/2	EPDM FDA / EPDM	ZU 1018/2
H/1	FFKM FDA	ZU 1020/1
H/2	FFKM FDA / FFKM FDA	ZU 1020/2
K/1	FFKM	ZU 1021/1
K/2	FFKM / FFKM	ZU 1021/2
<b>Spare Parts</b>		Order No.
Immersion tube, short	PTFE	ZU 1032
Immersion tube, long	PTFE	ZU 1033

**Dimension Drawings**

Installation dimensions WA 132  
Short immersion depth for sensors  
with solid electrolyte

Installation dimensions WA 132  
Long immersion depth for sensors  
with solid electrolyte

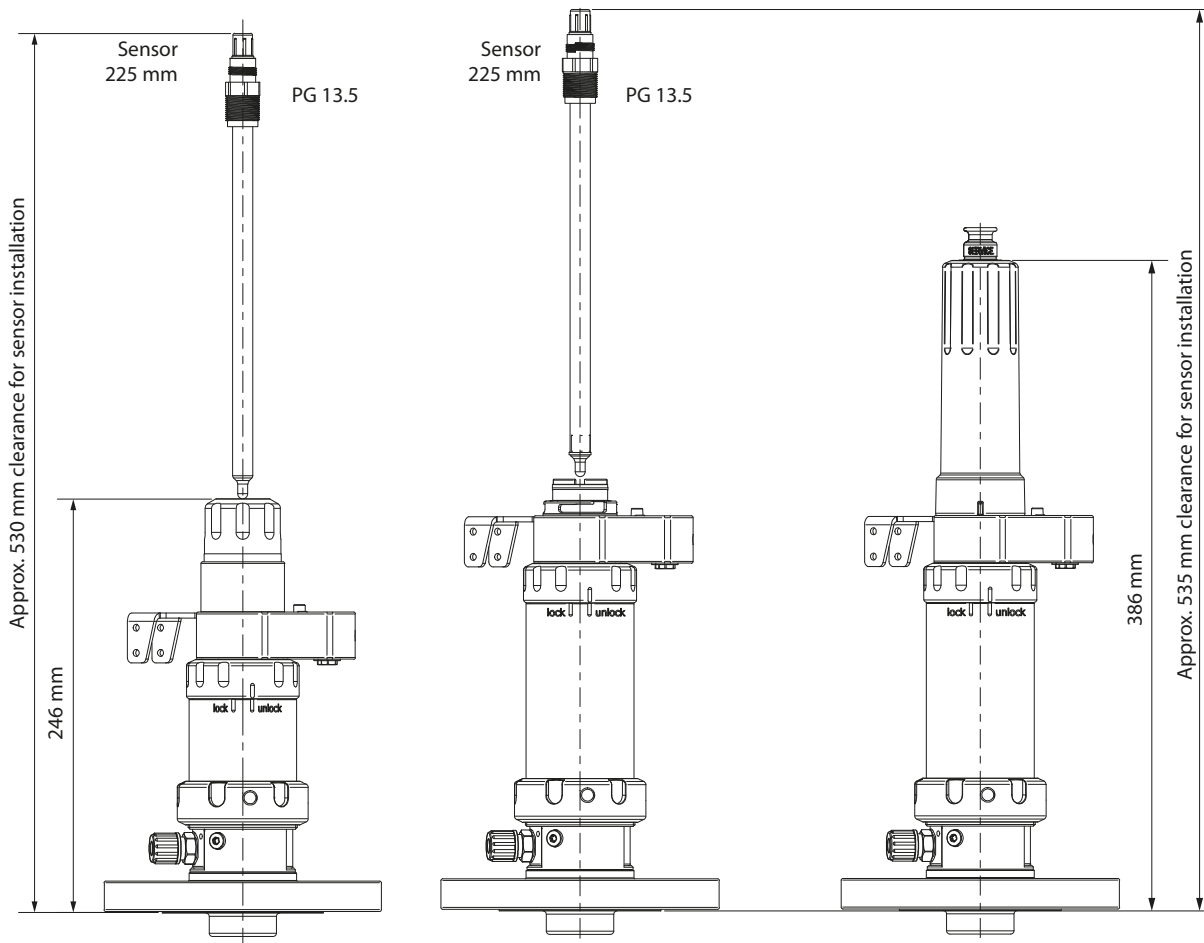

# SensoGate WA 132

## Dimension Drawings

Installation dimensions WA 132  
for sensors with liquid electrolyte

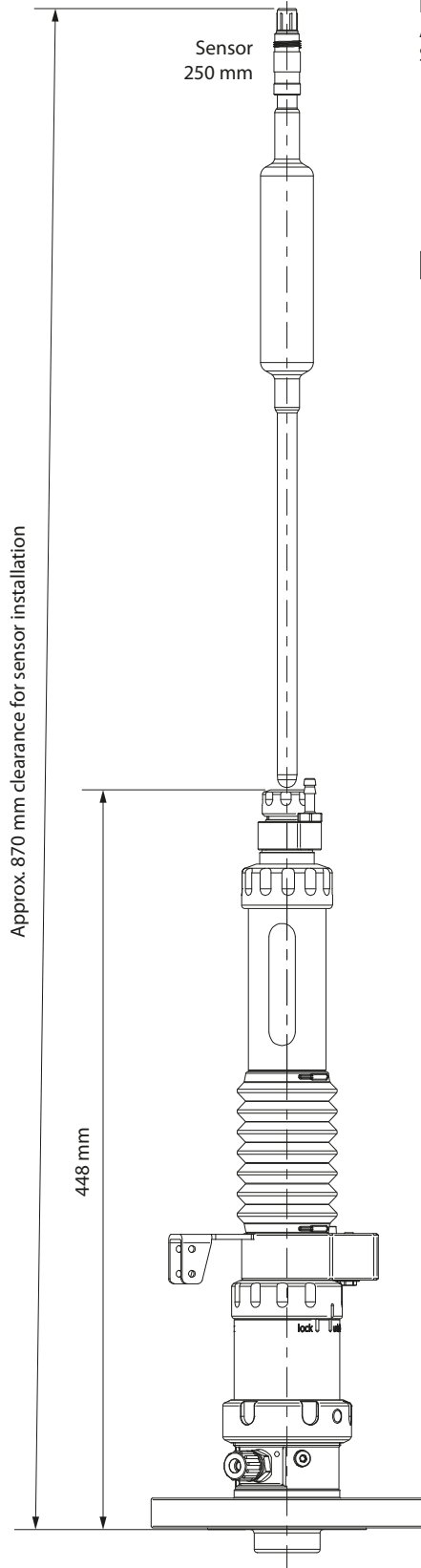

SensoGate WA 132  
Loose flange process connection  
DN 32 ... 100  
ANSI 316, 1 1/2" ... 3"  
Short immersion depth

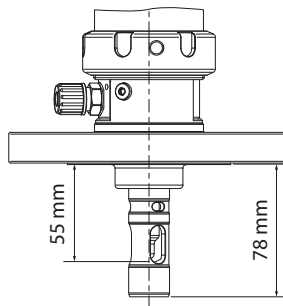

SensoGate WA 132  
Loose flange process connection  
DN 32 ... 100  
ANSI 316, 1 1/2" ... 3"  
Long immersion depth

