

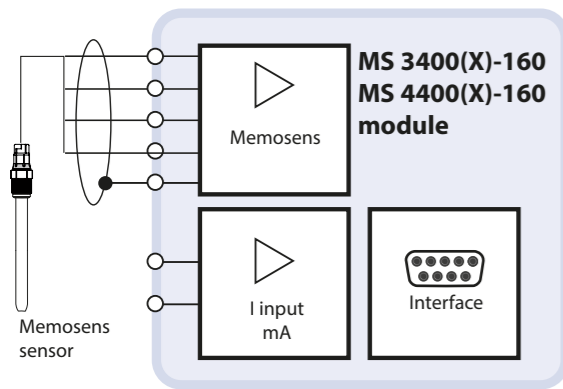

Read before installation.  
Keep for future use.



**Device Overview/Module Concept**



**Module Compatibility**

	Protos 3400	Protos 3400X	Protos II 4400	Protos II 4400X
Protos MS 3400-160 module	x		x <sup>*)</sup>	
Protos MS 3400X-160 module		x		x <sup>*)</sup>
Protos MS 4400-160 module			x	
Protos MS 4400X-160 module				x

<sup>\*)</sup> Module firmware version 03.01.00 or higher

Further information on the firmware version history can be found at [www.knick.de](http://www.knick.de).

**Safety**

Read the user manual for the basic unit (FRONT and BASE modules) and the corresponding measuring and communication modules, observe the technical specifications and follow the safety instructions in the safety guide (Package Contents for the basic unit Protos II 4400(X)) – for Ex versions, additionally the information provided in the documents in the Package Contents.

The user manual, safety guide and other product information can be downloaded from [www.knick.de](http://www.knick.de).

**Maintenance**

Protos modules cannot be repaired by the user. For inquiries regarding module repair, please contact Knick Elektronische Messgeräte GmbH & Co. KG at [www.knick.de](http://www.knick.de).

**Intended Use**

The module provides an RS-485 interface for the connection of Memosens sensors. It can be used to measure pH values, ORP, conductivity, and temperature. The TAN option also enables Memosens oxygen sensors to be connected. For pressure correction of oxygen sensors, there is an analog current input via which a pressure transmitter signal can be evaluated.

**Note:** The specifications on the module's rating plate take precedence.

**Package Contents**

- Measuring module
- Installation Guide
- Test Report 2.2 acc. to EN 10204
- Adhesive labels with terminal assignments
- For Ex version MS 3400X-160/4400X-160:
  - Appendix to certificates (KEMA 03ATEX2530, IECEx DEK 11.0054)
  - EU Declaration of Conformity
  - Control Drawings

Check all components for damage upon receipt. Do not use damaged parts.

**Operating states**

The function check (HOLD) operating state is active:

- During calibration (only the corresponding channel)
- During maintenance
- During parameter setting
- During the automatic rinse cycle (use of the rinse contact)

The behavior of the current outputs depends on the parameter setting, i.e., they may be frozen at the last measurement or set to a fixed value.

For detailed information, refer to the user manual for the basic unit (FRONT and BASE modules).

**Inserting the Module**

**CAUTION!** Electrostatic discharge (ESD). The modules' signal inputs are sensitive to electrostatic discharge. Take measures to protect against ESD before inserting the module and wiring the inputs.

**Note:** Strip the insulation from the wires using a suitable tool to prevent damage.

1. Switch off the power supply to the device
2. Open the device (loosen the 4 screws on the front)
3. Plug the module into the slot (D-SUB connector); see the figure below.
4. Tighten the module's fastening screws.
5. Connect the sensor cable.
6. Close the device by tightening the screws on the front.
7. Switch on the power supply
8. Make the parameter settings

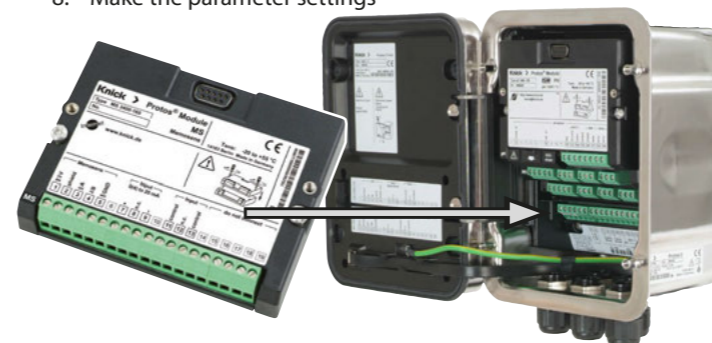

**CAUTION!** Risk of losing the specified ingress protection. Fasten the cable glands and screw together the housing correctly. Observe the permissible cable diameters and tightening torques (see the specifications of the basic unit). Insert blanking plugs or sealing inserts if necessary.

**Wiring**

Terminal	Wire color	Wiring for Memosens or M12 cable
1	Brown (BN)	Power supply +
2	transparent	Shield
3	Green (GN)	RS485 (A)
4	Yellow (YE)	RS485 (B)
5	White (WH)	Power supply – (GND)

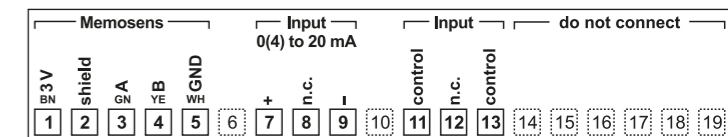

Copyright 2020 • Subject to change  
Version: 3

This document was published on November 13, 2020  
The latest documents are available for download on the website under the corresponding product description.



TI-201.160-KNEN03

**Headquarters**

Beuckestr. 22 • 14163 Berlin  
Germany  
Phone: +49 30 80191-0  
Fax: +49 30 80191-200  
info@knick.de  
www.knick.de

**Local Contacts**

[www.knick-international.com](http://www.knick-international.com)

## Menu Overview for the MS 3400(X)-160/4400(X)-160 Module

**⚠ CAUTION!** Incorrect parameter settings or adjustments can result in incorrect outputs. Protos II 4400(X) must therefore be commissioned by a system specialist, all its parameters must be set, and it must be fully adjusted.

Start by selecting the operating mode and process variable. Parameter Setting menu: MS ...-160 Module. Confirm with the "Apply" softkey. A restart will follow if you are using the MS 3400(X)-160 module with Protos 3400(X).

A connected Memosens sensor will immediately be displayed. All typical sensor parameters are automatically transferred to the analyzer. Measurement starts immediately without any further parameters having to be set. The measuring temperature is simultaneously detected. With "Plug&Measure", premeasured Memosens sensors can immediately be used for measurement without previous calibration.

### Parameter Settings for Memosens pH

Input filter	Pulse suppression
Sensor data	Sensoface, sensor monitoring
Cal presettings	Select buffer set, drift check, calibration timer, Cal tolerance band <sup>1)</sup>
TC process medium	Set the temperature compensation
Delta function	(output value = measurement – delta value)
Messages	pH value/mV value: off, max. device limits, variable limits

1) With Protos 3400(X) and add-on function SW3400-005

### Parameter Settings for Memosens ORP

Input filter	Pulse suppression
Sensor data	Conversion to SHE, Sensoface, sensor monitoring
Cal presettings	Calibration timer, ORP check: test time, test difference
Delta function	(output value = measurement – delta value)
Messages	ORP value: off, variable limits

### Parameter Settings for Memosens Oxy

SW3400-015/FW4400-015: Oxygen measurement	
Input filter	Pulse suppression
Sensor data	Measurement in liquids/gases, Sensoface, sensor monitoring
Cal presettings	Product calibration: saturation/concentration/partial pressure, calibration timer
Pressure correction	Pressure transmitter, current input, pressure during measurement/calibration
Salinity correction	Salinity, chlorinity, conductivity
Messages	Saturation %air <sup>2)</sup> , saturation %O <sub>2</sub> <sup>2)</sup> , concentration, partial pressure, air pressure (Monitoring is adjustable: off, variable limits)

2) Only for measurements in liquids

### Parameter Settings for Memosens Cond

Input filter	Pulse suppression
Sensor data	Sensoface, sensor monitoring
Cal presettings	Select calibration solution (NaCl/KCl), product calibration via conductivity/concentration <sup>3)</sup>
TC process medium	Set the temperature compensation (off, linear, EN 27888, ultrapure water <sup>4)</sup> )
Concentration	With add-on function SW3400-009/FW4400-009
Messages	Conductivity, resistivity, concentration, temperature, salinity. Can be adjusted for all types of monitoring: off, max. or variable device limits
USP function	Monitoring of ultrapure water

### Parameter Settings for Condi

Input filter	Pulse suppression off, on
Sensor data	Sensoface, sensor monitoring
Cal presettings	Select calibration solution (NaCl/KCl), product calibration via conductivity/concentration <sup>3)</sup>
TC process medium	Set the temperature compensation (off, linear, EN 27888, ultrapure water <sup>4)</sup> )
Concentration	With add-on function SW3400-009/FW4400-009
Messages	Conductivity, resistivity, concentration, temperature, salinity. Can be adjusted for all types of monitoring: off, max. or variable device limits

3) With Protos II 4400(X) and add-on function FW4400-009

4) With add-on function SW3400-008/FW4400-008

### Calibration/Adjustment

pH	Calimatic automatic calibration/adjustment, manual cal., product calibration/adjustment, data entry, temperature probe adjustment (with Protos II 4400(X))
ORP	ORP calibration/adjustment, temperature probe adjustment (with Protos II 4400(X))
Oxy	Automatic (water/air), product calibration/adjustment, data entry, zero correction, temperature probe adjustment (with Protos II 4400(X))
Cond	Automatic with standard calibration solution, manual cal., product calibration/adjustment, data entry, temperature probe adjustment (with Protos II 4400(X))
Condi	Automatic with standard calibration solution, manual cal., product calibration/adjustment, data entry, zero correction, temperature probe adjustment (with Protos II 4400(X))

### Maintenance

Sensor monitor	For validation of sensor and complete signal processing
Temp. probe adjustment	(with Protos 3400(X))

### Diagnostics

Message list	List of all messages
Logbook	Shows the last events with date and time
Meas. point description	Shows the tag number and annotation (input in system control)
Device description	Hardware version, serial number, (module) firmware, options
Module diagnostics	Internal function test
Sensor monitor	Shows the values currently measured by the sensor
Cal/adj record	Dates of the last adjustment/calibration
Sensor diagram (pH/Oxy)	Graphic display of the current sensor parameters
Sensor wear monitor	Current sensor wear, sensor operating time, max. temperature

## Messages/Troubleshooting

(for detailed tables, see the user manual)

Error	Message (Diagnostics menu: Message list)	Possible causes	Remedy
	Display is blank	FRONT or BASE power supply interrupted Input fuse has tripped Display switch-off is active	Check the power supply Replace the fuse (500 mA T) Deactivate the display switch-off
	No measurement, no error message	Module not plugged in correctly	Install the module correctly Check the measurement display under "Parameter setting > Administrator level > FRONT Module"
	Sensoface ☹	Sensor not calibrated/adjusted Glass impedance too high, sensor cable defective  Glass impedance too low: Possible glass breakage on sensor, sensor cable defective	Calibrate and adjust Calibrate and adjust Check the sensor connection Clean and replace the sensor if necessary Replace the sensor cable  Replace the sensor Replace the sensor cable
B073/ B078	Current I1/I2, load error	Open current output I1/I2: Current loop not closed, cable interrupted	Check the current loop Deactivate the current outputs
F232	Module configuration Ex/safe area	Ex and safe area modules have been inserted.	Select a uniform configuration (either Ex or safe area)
...010	Measuring range	No sensor connected, sensor cable defective	Connect the sensor, check the sensor cable, and replace if necessary
...015	Temperature range	Sensor connected incorrectly Wrong operating mode selected	Check the sensor connection Adjust the operating mode
...120	Wrong sensor	Sensor does not match the selected process variable	Replace the sensor, change the process variable
...121	Sensor error	Error in default/specific data, sensor is defective.	Replace the sensor

## Specifications (Excerpt)

Memosens	Interface for Memosens
Power supply	U <sub>0</sub> = 3.05 ... 3.15 V/R <sub>i</sub> < 5 Ω / I ≥ 6 mA
Ex (MS 3400X-160/ MS 4400X-160)	Ex ia IIC T4; U <sub>max</sub> = 5.1 V / I <sub>max</sub> = 130 mA / P <sub>max</sub> = 166 mW
Interface	RS-485
Transfer rate	9,600 Bd
Max. cable length	100 m
I input	Current input 0/4 ... 20 mA / 100 Ω e.g., for external pressure signal with OXY
Start/end of scale	Can be configured within range
Characteristic curve	Linear
Measurement error	< 1% current value + 0.1 mA (± 1 count, plus sensor error)
RoHS conformity	According to EU directive 2011/65/EU
EMC	EN 61326-1, EN 61326-2-3, NAMUR NE 21
Emitted interference	Industrial applications <sup>1)</sup> (EN 55011 Group 1 Class A)
Interference immunity	Industrial applications
Lightning protection	According to EN 61000-4-5, installation class 2

Rated operating conditions (module installed)

Ambient temperature	Safe area: -20 ... 55 °C / -4 ... 131 °F Ex: -20 ... 50 °C / -4 ... 122 °F
Relative humidity	5 ... 95 %
Climatic class	3K5 according to EN 60721-3-3
Location class	C1 according to EN 60654-1
Transport/storage temperature	-20 ... 70 °C / -4 ... 158 °F
Screw clamp connector	Tightening torque 0.5 ... 0.6 Nm Single or stranded wires 0.2 ... 2.5 mm <sup>2</sup> Stripping length max. 7 mm Temperature resistance > 75 °C / 167 °F
Wiring	
Power supply (KBUS)	6.8 ... 8.0 V / 20 mA

1) This equipment is not designed for domestic use, and is unable to guarantee adequate protection of the radio reception in such environments.